



We
protect
what
matters
most™

EverGuard® TPO/PVC Mechanically Attached and Drill-Tec™ RhinoBond® Retrofit Roofing Systems Over Metal Roofs

**A Guide to Metal Roof Retrofit in Commercial Low-slope Roof
Assemblies**

Prepared by GAF Technical Services
December, 2020

Table of Contents

Page

Introduction

About GAF	3
Important Considerations	3

Guarantee Program

Guarantee Lengths	5
-------------------	---

Available Roll Sizes

6

Roof Design

Recover	7
Existing Metal Roof System As The Substrate	7
Fire Resistance	7
Wind Performance	8
Structural Performance	10
Drainage Concerns	14

Attachment Tables

TPO & PVC Purlin Attachment Table - Mechanically Attached Systems	15
TPO & PVC Purlin Attachment Table - Drill-Tec™ RhinoBond® Attached Systems	16

Specification Plates

TPO Mechanically Attached - Every Purlin	17
PVC Mechanically Attached - Every Purlin	18
TPO Mechanically Attached - Every Other Purlin	19
PVC Mechanically Attached - Every Other Purlin	20
TPO Drill-Tec™ RhinoBond® Attachment System	21
PVC Drill-Tec™ RhinoBond® Attachment System	22

Design Considerations & Application Guidelines

Substrate Surface Preparation & Site Conditions	23
Fasteners & Plates	24
Insulation & Flute Filler	24
Membrane Installation – Mechanically Attached Roofing System into Purlins	25
Membrane Placement	25
Membrane Securement	25
Membrane Installation – Drill-Tec™ RhinoBond® Roofing System into Purlins	26
Membrane Placement	26
Membrane Securement	26

Published 12/2020

EverGuard® Metal Retrofit

Roofing Details

Drill-Tec™ RhinoBond® Assembly Purlin Detail	28
Mechanically Attached Assembly Purlin Detail – Fasteners Located in Seams	29
Mechanically Attached Assembly Purlin Detail – Fasteners Stripped In	30
Purlin Fastening Zones – Drill-Tec™ RhinoBond® Assembly	31
Purlin Fastening Zones – Mechanically Attached Assembly, Every Purlin	32
Purlin Fastening Zones – Mechanically Attached Assembly, Every Other Purlin	33
Metal Roof Ridge Detail – Drill-Tec™ RhinoBond® Assembly	34
Metal Roof Ridge Detail – Mechanically Attached Assembly	35
Metal Roof Edge Detail	36
Metal Roof Gutter Detail	37
Appendix A: Design Parameters	38
Appendix B: Alternative Design Parameters	39

Note: Refer to www.gaf.com for a complete list of Product Data Sheets and Chemical Resistance Guides.

Introduction

Thank you for consulting the EverGuard® TPO/PVC Mechanically Attached and Drill-Tec™ RhinoBond® Retrofit Roofing Systems Over Metal Roofs. You can find further information at www.gaf.com, or contact GAF Technical Support and Services at 1-800-ROOF-411 (1-800-766-3411).

This Guide serves as a supplement to the EverGuard® TPO/PVC Mechanically Attached and Drill-Tec™ RhinoBond® Roofing System Overview & General Requirements Manuals.

About GAF

Founded in 1886, GAF is the largest roofing manufacturer in North America.

As the industry leader, GAF proudly offers a comprehensive portfolio of award-winning, innovative roofing products for both steep-slope and commercial properties. Supported by an extensive national network of factory-certified contractors, GAF has built its reputation – and its success – on its steadfast commitment to Advanced Quality, Industry Expertise, and Solutions Made Simple.

GAF offers all major low-slope roofing technologies, including repair and maintenance products and roof restoration systems, as well as new roofing systems (BUR, modified bitumen, TPO, PVC, and liquid-applied roofing). GAF has developed single-ply, asphaltic and liquid-applied membranes with excellent durability to meet the most rigorous industry standards.

For more information, visit www.gaf.com.

Important Considerations

The purpose of this Guide is to provide fundamental information on mechanically attached metal roof retrofits and recommendations on addressing mechanically attached metal roof retrofits in low-slope roof assemblies.

- This Guide contains the latest information relating to the application of GAF's EverGuard® TPO/PVC Mechanically Attached and Drill-Tec™ RhinoBond® Retrofit Roofing Systems Over Metal Roofs. It has been prepared as a general guide to assist architects, engineers, roofing contractors, and owners in the use of our roofing systems.
- GAF manufactures and sells roofing materials and does not practice architecture or engineering. GAF is not responsible for the performance of its products when damage to its products is caused by such things as improper building design, construction flaws, or defects in workmanship.
- The design responsibility remains with the architect, engineer, roofing contractor or owner, and construction details illustrated and described herein are furnished solely for guidance purposes. These guidelines should not be construed as being all-inclusive, nor should they be considered as a substitute for good application practices. Please consult your design professional for more information.
- Under no circumstances shall GAF have any liability for expenses arising out of or associated with the pre-existing presence of asbestos-containing materials or any other allegedly hazardous

substances or materials upon the roof to which the new GAF roofing materials are being applied.

- Information contained in this Manual is presented in good faith and, to the best of GAF's knowledge, does not infringe upon any patents, foreign or domestic.
- As a part of its continuing efforts to improve the performance of its products, GAF periodically makes changes to its products and application specifications. The Company reserves the right to change or modify, at its discretion, any of the information, requirements, specifications, or policies contained herein. This Guide supersedes all catalogs and previous manuals.
- This Guide serves as a supplement to the EverGuard® TPO/PVC Mechanically Attached and Drill-Tec™ RhinoBond® Roofing System Overview & General Requirements Manuals.

Guarantee Program

GAF offers roof guarantees for a fee for all roofing system specifications published in this Guide when installed by GAF Factory-Certified Low-Slope Roofing Contractors in accordance with the terms and conditions set forth in this Manual, and provided that all procedures for obtaining a guarantee are followed.

All guaranteed roofing systems must be flashed in accordance with published GAF flashing requirements and details. All GAF insulation, fasteners, pre-flashed details, expansion joint covers, cements, coatings, and accessory products as job appropriate are required for guarantees unless otherwise approved in writing by a Field Services Manager or Director prior to installation.

GAF will be the sole judge as to whether a guarantee will be issued to cover any proposed or completed roof. The issuance of a guarantee and its effectiveness or the continued liability thereunder is contingent upon payment of GAF's guarantee fee and payment in full to contractors and materials suppliers.

GAF has no obligation to issue a roofing guarantee on any roof. Any inspection prior to issuance is **solely** for the benefit of GAF and does not constitute a waiver of any terms or conditions in the guarantee. In the event that a roof system does not conform to GAF's standards and a guarantee is not issued, no portion of the guarantee fee is refundable.

GAF will not accept Notices of Award of Contract that indicate that the owner or architect has the option to accept or reject the guarantee upon completion of the roof.

Specifications not listed in this Guide may also be eligible for GAF guarantees. For further information on guarantee requirements and for approval of modifications to published specifications, consult with GAF at 800-766-3411.

GAF is not responsible for consequential damages in case of roof system failure. GAF has no control over a building's contents, type, quantity, positioning, or protection.

Guarantees Lengths

GAF offers a selection of roof guarantees to meet the needs of most building owners. The following guarantees are available for use with selected EverGuard® TPO/PVC Mechanically Attached and Drill-Tec™ RhinoBond® Retrofit Roofing Systems Over Metal Roofs when installed by an eligible GAF factory-certified contractor. GAF EverGuard® roof membranes must be used in roofing systems to be guaranteed by GAF. **The maximum guarantee length for any metal retrofit system is 20 years.**

Maximum roof slope: 2:12

Maximum building height: 40 feet (18.3 m)

Maximum enhanced wind speed coverage available: up to 72 mph, on eligible projects only; advanced written approval from GAF required.*

TPO Guarantee Lengths¹

System Attachment	Maximum Guarantee Length	EverGuard® TPO	EverGuard Extreme® TPO
Mechanically Attached	20 years	60, 80 mils	50, 60, 70, 80 mils
Plate Welded (Drill-Tec™ RhinoBond®)	20 years	45, 60, 80 mils	50, 60, 70, 80 mils

PVC Guarantee Lengths¹

System Attachment	Maximum Guarantee Length	EverGuard® PVC	EverGuard® PVC XK
Mechanically Attached	15 years	50, 60, 80 mils	50, 60, 80 mils
	20 years	60, 80 mils	60, 80 mils
Plate Welded (Drill-Tec™ RhinoBond®)	15 years	50, 60, 80 mils	50, 60, 80 mils
	20 years	60, 80 mils	50, 60, 80 mils

¹Smooth membrane only. **The use of fleeces-back membrane is not permitted.**

* Standard wind speed coverage under GAF guarantees is 55 mph. See guarantee for coverage and restrictions.

Available Roll Sizes

The following is a list of available roll sizes by product type:

Product	Membrane Thickness	Available Roll Size (width x length)
EverGuard® PVC	50 and 60 mils	10' x 100' (3.05 x 30.5 m)
	80 mils	10' x 80' (3.05 x 24.4 m)
EverGuard® PVC XK	50 and 60 mils	10' x 100' (3.05 x 30.5 m)
	80 mils	10' x 80' (3.05 x 24.4 m)
EverGuard® TPO	45 and 60 mils	6' x 100' (1.83 x 30.5 m) 8' x 100' (2.44 x 30.5 m) 10' x 100' (3.05 x 30.5 m) 12' x 100' (3.66 x 30.5 m)
	80 mils	10' x 100' (3.05 x 30.5 m)
EverGuard Extreme® TPO	50 and 60 mils	8' x 100' (2.44 x 30.5 m) 10' x 100' (3.05 x 30.5 m)
	70 and 80 mils	10' x 100' (3.05 x 30.5 m)

Roof Design

GAF does not practice architecture or engineering. This section is provided for guidance purposes only. There are many factors that may affect roof design, including specific job site conditions, local building codes, building use, etc., which must be taken into account. GAF recommends consultation with a design professional to determine specific roofing needs and requirements for each particular project.

Proper roofing system design and selection requires the consideration of many factors. Although GAF's expertise is in materials manufacturing, and not in engineering, architecture, or specialized roof consulting, our company has decades of experience in the practical aspects of roofing. Our experience suggests that careful consideration of the following will provide a fundamentally sound basis for design and selection of EverGuard® TPO/PVC Mechanically Attached and Drill-Tec™ RhinoBond® single-ply roofing systems.

Re-Cover

The basis for any re-cover project is to eliminate defects in the existing roof assembly so that their effect on the new roofing system is minimized. At a minimum, attention to the following considerations is recommended:

- Raise all perimeter flashings, penetrations, and equipment to provide required flashing heights;
- Address drainage deficiencies to provide positive drainage; and
- Concentrate on thorough surface preparation.

Existing Metal Roof System As The Substrate

It is the responsibility of the engineer, architect, building owner, or roofing contractor to determine the fitness of an existing metal panel roof system that will be serving as a substrate for a specific roofing system installation. Additionally, GAF is not responsible for moisture related problems associated with any deck or substrate materials.

Fire Resistance

Exterior Fire Resistance: Resistance by the roofing system to fire applied to the exterior roof surface is important. Typically, a UL Class A or B rating is required by building code.

Interior Fire Resistance: Depending on the building's use and occupancy, and construction type, resistance to fire from within the building will be required. This is normally expressed in the form of hourly ratings, and usually requires the use of a tested roof assembly.

Refer to current EverGuard® listings in the appropriate UL directory or Factory Mutual Approval Listings to verify roof assembly requirements for specific fire ratings.

Thermal Barrier Requirements: The International Building Code has requirements when foam plastic insulation (e.g., polyiso) is used in a roof assembly. A thermal barrier is required to separate the foam plastic insulation from the interior of a building except when a roof assembly passes one of the following tests:

- FM 4450, “Approval Standard for Class 1 Insulated Steel Decks Roofs”
- NFPA 276, “Standard Method of Fire Test for Determining the Heat Release Rate of Roofing Assemblies with Combustible Above-Deck Roofing Components”
- UL 1256, “Standard for Fire Test of Roof Deck Constructions”

Wind Performance

Ideally, roofing systems should be capable of resisting the forces generated by the maximum anticipated wind speed for a specific building. One widely accepted method for specifying wind performance is to require the appropriate FM 1-60, 1-90, or other rated system as appropriate for a specific building based upon location, exposure, and other factors.

The following are common standards and approvals typically used in conjunction with wind performance of EverGuard® roofing systems:

- Factory Mutual Approvals
 - Testing based on method described in Approval Standards 4450 and 4470.
 - Measures resistance to upward pressure applied to the roof system.
- American Society of Civil Engineers (ASCE) document ASCE 7, “Minimum Design Loads for Buildings and Other Structures”
 - A comprehensive analysis of wind forces acting on buildings.
 - Requires detailed calculations to determine actual wind pressures at different regions of the roof.
 - Referenced by building codes.

Corner and Perimeter Attachment: Additional fasteners are required in corner and perimeter areas of the roof, because wind pressures are increased in the corners, with somewhat lower increased pressures acting along the remaining roof perimeter. The following details may be used as a fastening guide for corner and perimeter zones:

- Detail 101F: Purlin Fastening Zones – Drill-Tec™ RhinoBond® Assemblies
- Detail 101G: Purlin Fastening Zones – Mechanically Attached Assemblies Every Purlin
- Detail 101H: Purlin Fastening Zones – Mechanically Attached Assemblies Every Other Purlin

Wind Load for Metal Roof Retrofits: TPO/PVC mechanically attached retrofit roofing systems over metal panels on metal buildings should be attached to existing purlins, not the metal panels, to ensure a proper wind-uplift load path. See Figure 1. For conventional mechanically attached roofing systems, they may be fastened into every purlin (e.g., every 5 feet [1.52 m]) or fastened into every other purlin (e.g., every 10 feet [3.05 m]). For Drill-Tec™ RhinoBond® attached roofing systems, they should be fastened into every purlin.

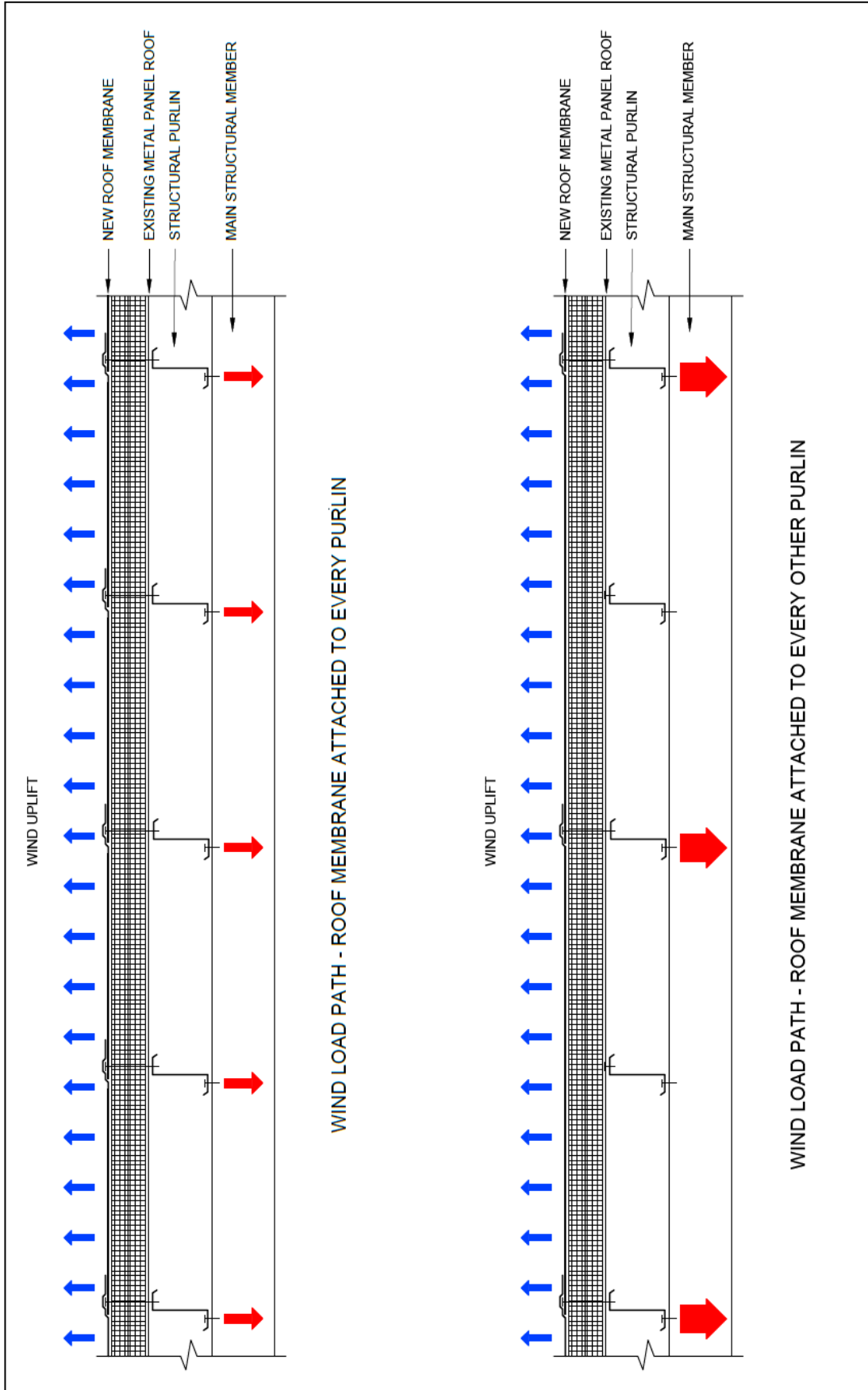

Figure 1: Illustration of Wind Load Path

Additional purlins may need to be installed in corners and perimeters to provide appropriate attachment locations for fasteners in order to achieve desired wind uplift resistance.

If possible, examine the underside of existing metal panel roof system to confirm the existence of supplemental purlins at corner, perimeter and/or ridge areas. If supplemental purlins exist, the roof membrane should be mechanically attached to these purlins per the fastening patterns applicable for the roof zone.

Wind Load Testing: The following standards are commonly used to determine the wind resistance (i.e., uplift) for roofing systems.

- **ASTM E1592**, “Standard Test Method for Structural Performance of Sheet Metal Roof and Siding Systems by Uniform Static Air Pressure Difference.” ASTM E1592 covers the evaluation of the structural performance of sheet metal panels and anchor-to-panel attachments.
- **FM 4474**, American National Standard for Evaluating the Simulated Wind Uplift Resistance of Roof Assemblies Using Static Positive and/or Negative Differential Pressures.” FM 4474 evaluates simulated wind uplift resistance of complete roof assemblies by using static pressure differentials.
- **UL 580**, “Standard for Tests for Uplift Resistance of Roof Assemblies.” UL 580 evaluates the roofing system and the roof deck attachment to the supports.
- **UL 1897**, “Standard for Uplift Tests for Roof Covering Systems.” UL 1897 evaluates a roof covering system’s method of attachment, including all components, by using differential air pressures.

Some components of a roof deck system are not evaluated by these test methods. For example, secondary supports such as beams, purlins and joists, and the connections from secondary supports to the main structural system, are not evaluated.

It is imperative that the attachment capacity of the purlins to the secondary structure is greater than the attachment capacity of the metal panels to the purlins.

Structural Performance

There are structural design considerations when installing a TPO/PVC mechanically attached retrofit roofing system over existing metal roof panels on a metal building, such as:

- Dead load: Additional dead load may come from two sources:
 - Added weight of the new roof (albeit minimal), and
 - Added loads during winter from a lack of melted snow due to reduced heat loss from the insulation upgrade in the retrofit roof system.

Additionally, if the building is located in a jurisdiction that adopted the 2012, 2015 or 2018 International Existing Building Code (IEBC) and any one of the two conditions listed below occur due to reroofing, then the affected structural elements carrying the increased loads must be

altered, strengthened or replaced with heavier members to meet International Building Code (IBC) design criteria:

1. The metal roof retrofit caused an increase in design dead, live or snow load (drift effects) of more than 5% of the original design; or
 2. The second layer of roof covering weighs more than 3 pounds per square foot.
- **Drag Load:** Drag load is a load that runs parallel to a sloped roof surface. With low-slope roof systems (i.e., 2:12 or less), the effect of drag load typically is insignificant. However, drag loads can pull metal roof panels down the slope of a roof. Factors that contribute to drag load are the weight of the roof system itself, and the additional weight of snow and ice. Drag load increases as roof slope increases. With a single-ply membrane retrofit system, drag loads are resisted by:
 - Attachment of the metal roofing panels to the structural purlins; Drag loads may be large enough to cause structural purlins to “roll.”
 - Lateral loading on the membrane fasteners. The greater the insulation depth, the greater the bending load on the fasteners.
 - **Purlin Continuity:** The most common purlin types are “Z” and “C” shaped sections. In many metal buildings, purlins are continuous over rigid steel frames or rafters, which serve as structural supports for the purlins.

Purlins are commonly lapped at the supports to achieve continuity. With “Z” purlins, purlins are typically lapped by nesting one inside another, see Figure 2. However with “C” purlins, purlins often are connected back-to-back for continuity, see Figure 3, and under these circumstances, a straight row of fasteners will not be achievable.

Where the “C” purlins are installed back-to-back, GAF recommends appropriate measures be taken, so that adjustment is made in the fastening pattern to ensure the attachment of the roofing system engages into the structural purlins.

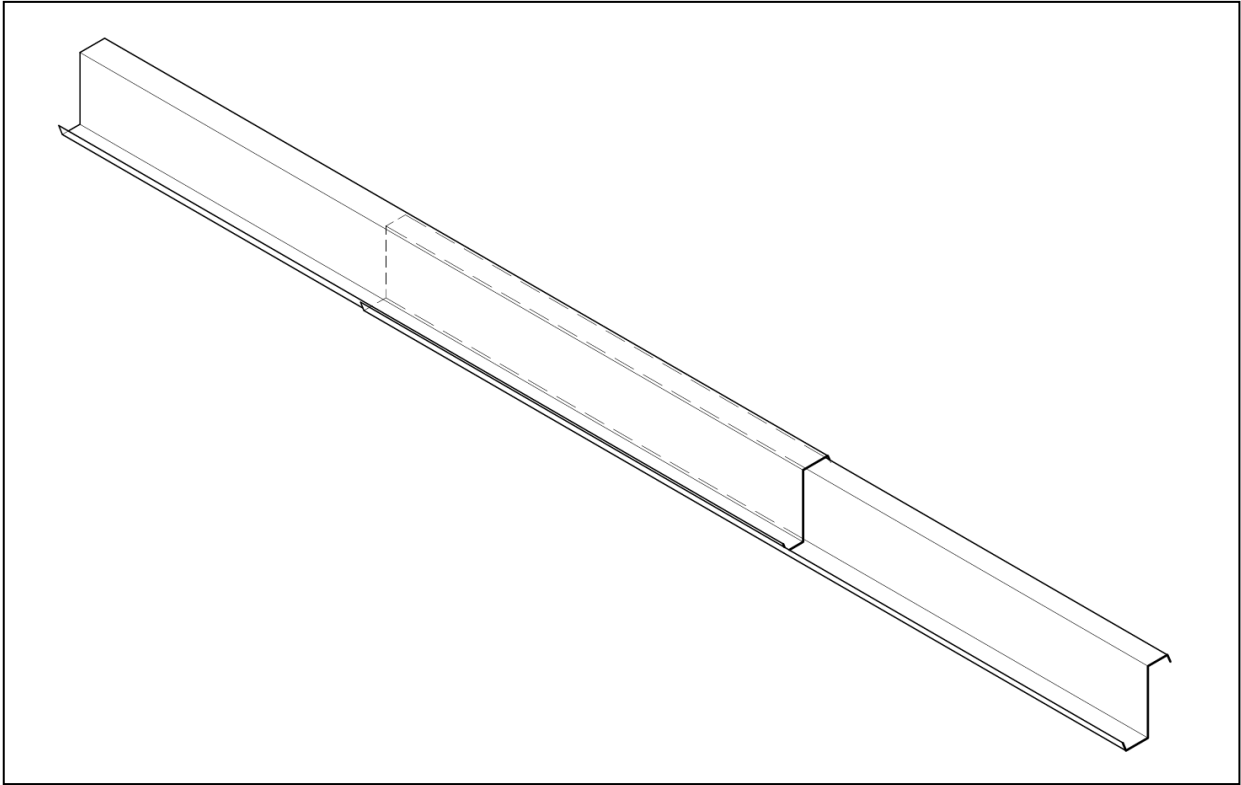

Figure 2: "Z" purlins lapped by nesting

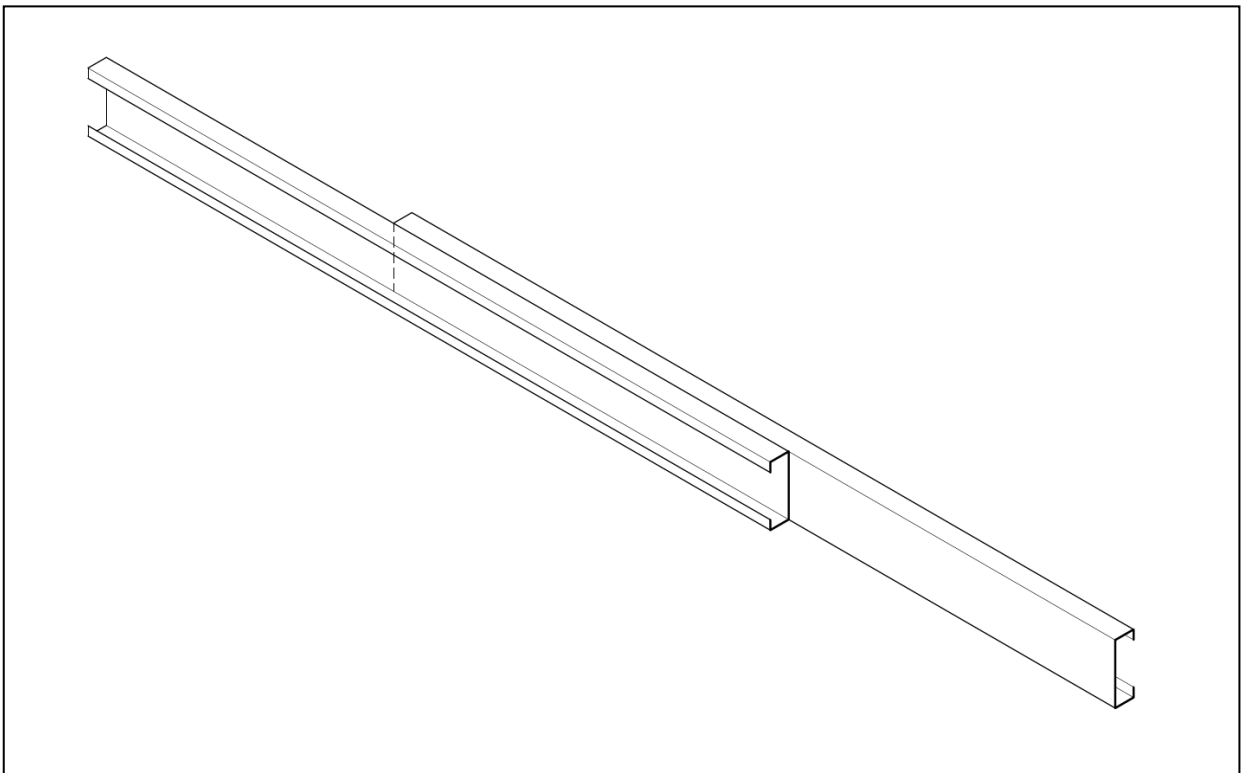

Figure 3: "C" purlins lapped back-to-back

- **Lateral Bracing:** Lateral Bracing is used to mitigate the effects of stress on structural members and is critical in resisting wind loads. In metal buildings, purlins should be braced to guard against bending, rotation or deformation.

Special attention should be paid to metal panel roofing systems with exposed fasteners, a.k.a. through-fastened metal roofs. With these types of applications, the metal panels are often relied upon to provide the diaphragm action to stiffen the building and brace the purlins. This may not be adequate for a metal roof retrofit. GAF recommends a licensed design professional be retained to evaluate the needs for the specific project.

GAF recommends purlins be braced when installing a mechanically attached single-ply over an existing metal panel roof system. See Figure 4 for examples of bracing.

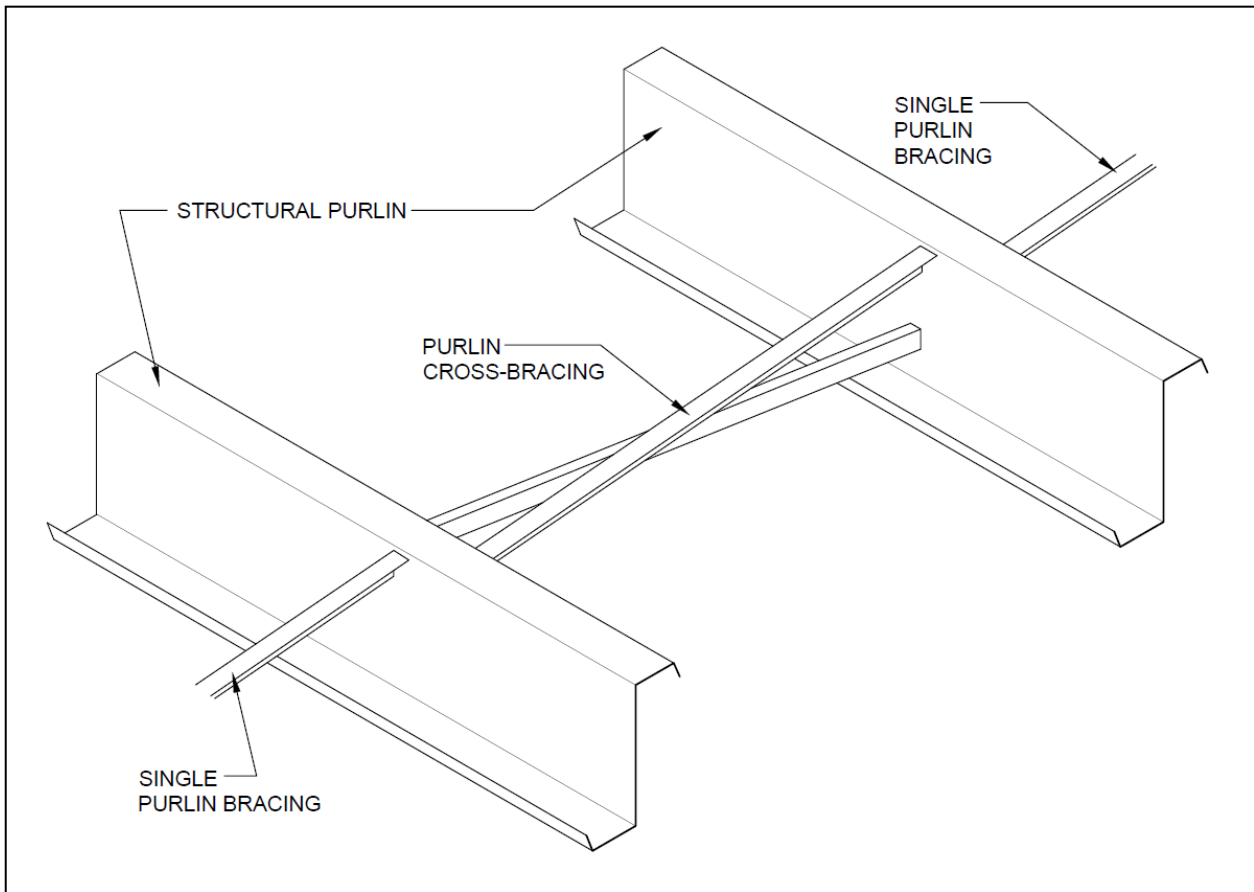

Figure 4: Examples of purlin bracing

Drainage Concerns

On metal panel roofing systems, water drains between the seams of metal roof panels. Since the water is confined to individual panel sections, this results in a uniform load on the structural system. Metal buildings are typically designed for balanced loading; therefore, equal loading across the purlins is critical. When a single-ply membrane is installed over a metal panel roof system, the water flow pattern is changed, because water is no longer confined by the panel seams.

Certain conditions can lead to ponded water, which may produce uneven loading of the structure. The following may contribute or exacerbate uneven loading situations due to ponding:

- Clogged gutters or scuppers, especially buildings with parapets or built-in (internal) gutters
- Surge of water as a result of a mechanically-attached single-ply membrane billowing from high winds
- Damaged or overloaded purlins
- Deflection in metal roof panels

TPO/PVC PURLIN ATTACHMENT TABLE

MECHANICALLY ATTACHED SYSTEMS

Maximum roof slope = 2:12

Maximum building height = 40 feet (18.3 m)

Maximum enhanced wind speed coverage available: up to 72 mph, on eligible projects only; advanced written approval from GAF required.*

Max. Purlin & Fastener Row Spacing ⁵	Purlin Type ¹	Min. Pull-out Value (lbs/fastener) ²	Max. Fastener Spacing Field Zones of Roof ⁵	Max. Fastener Spacing Perimeter Zones of Roof ^{3,4}	Max. Fastener Spacing Corner Zones of Roof ^{3,4}
Up to 5 ft. (1.52 m) [every purlin]	Min. 16 ga.	800	12" o.c.	10" o.c.	8" o.c.
	Min. 14 ga.	1000	18" o.c.	12" o.c.	9" o.c.
	Min. 12 ga.	1000	18" o.c.	12" o.c.	9" o.c.
Up to 10 ft. (3.05 m) [every other purlin]	Min. 16 ga.	800	6" o.c.	10" o.c.	8" o.c.
	Min. 14 ga.	1000	9" o.c.	12" o.c.	9" o.c.
	Min. 12 ga.	1000	9" o.c.	12" o.c.	9" o.c.

1. The attachment capacity of the purlins to the secondary structure must be greater than the attachment capacity of the metal panels to the purlins, especially when an "every other purlin" attachment method is used.
2. Fastener pull-out testing is recommended.
3. Install fasteners into every purlin in perimeter and corner zones.
4. Refer to Detail 101G for attachment information for every purlin roofing systems and Detail 101H for every other purlin roofing systems.
5. See Appendix A for design parameters. For alternative design parameters, see Appendix B.

Fastener Pullout Testing

Fastener pull-out testing in accordance with ANSI/SPRI FX-1 2016 Standard Field Test Procedure for Determining the Withdrawal Resistance of Roofing Fasteners is recommended. Minimum 1" (25 mm) Drill-Tec™ Purlin Fastener embedment is required. Fastener pullout tests shall be conducted on the purlins with approved fasteners. Roof sections with low pullout results will require additional pullout tests or additional purlins.

* Standard wind speed coverage under GAF guarantees is 55 mph. See guarantee for coverage and restrictions.

TPO/PVC PURLIN ATTACHMENT TABLE

DRILL-TEC™ RHINOBOND® ATTACHED SYSTEMS

Maximum roof slope = 2:12

Maximum building height = 40 feet (18.3 m)

Maximum enhanced wind speed coverage available: up to 72 mph, on eligible projects only; advanced written approval from GAF required.*

Max. Purlin & Fastener Row Spacing ⁶	Purlin Type ^{1,2}	Min. Pull-out Value (lbs/fastener) ³	Max. Fastener Spacing Field of Roof ^{4,5}	Max. Fastener Spacing Perimeter Zones of Roof ⁵	Max. Fastener Spacing Corner Zones of Roof ⁵
Up to 5 ft. (1.52 m) [every purlin]	Min. 16 ga.	800	24" o.c.	10" o.c.	8" o.c.
	Min. 14 ga.	1000	24" o.c.	12" o.c.	9" o.c.
	Min. 12 ga.	1000	24" o.c.	12" o.c.	9" o.c.

1. Membrane must be attached to the Drill-Tec™ RhinoBond® Plates that are installed directly into structural purlins with appropriate Drill-Tec™ Purlin Fastener. The special TPO coating on the plates allows for EverGuard® TPO membrane to be welded to each plate using the RhinoBond® magnetic induction welding tool. Drill-Tec™ RhinoBond® Plates are different in type and color: TPO plates are a yellow/green, while the PVC plates are black in color. The appropriate plate must be used with the appropriate membrane type.
2. The attachment capacity of the purlins to the secondary structure must be greater than the attachment capacity of the metal panels to the purlins.
3. Fastener pull-out testing is recommended.
4. Fasteners should be offset 12" (305 mm) between rows.
5. Refer to Detail 101F for attachment information for Drill-Tec™ RhinoBond® roofing system, including how to achieve offset in fastening pattern.
6. See Appendix A for design parameters.

Fastener Pullout Testing

Fastener pull-out testing in accordance with ANSI/SPRI FX-1 2016 Standard Field Test Procedure for Determining the Withdrawal Resistance of Roofing Fasteners is recommended. Minimum 1" (25 mm) Drill-Tec™ Purlin Fastener embedment is required. Fastener pullout tests shall be conducted on the purlins with approved fasteners. Roof sections with low pullout results will require additional pullout tests or additional purlins.

* Standard wind speed coverage under GAF guarantees is 55 mph. See guarantee for coverage and restrictions.

TPO MECHANICALLY ATTACHED SYSTEMS SPECIFICATION PLATE - EVERY PURLIN

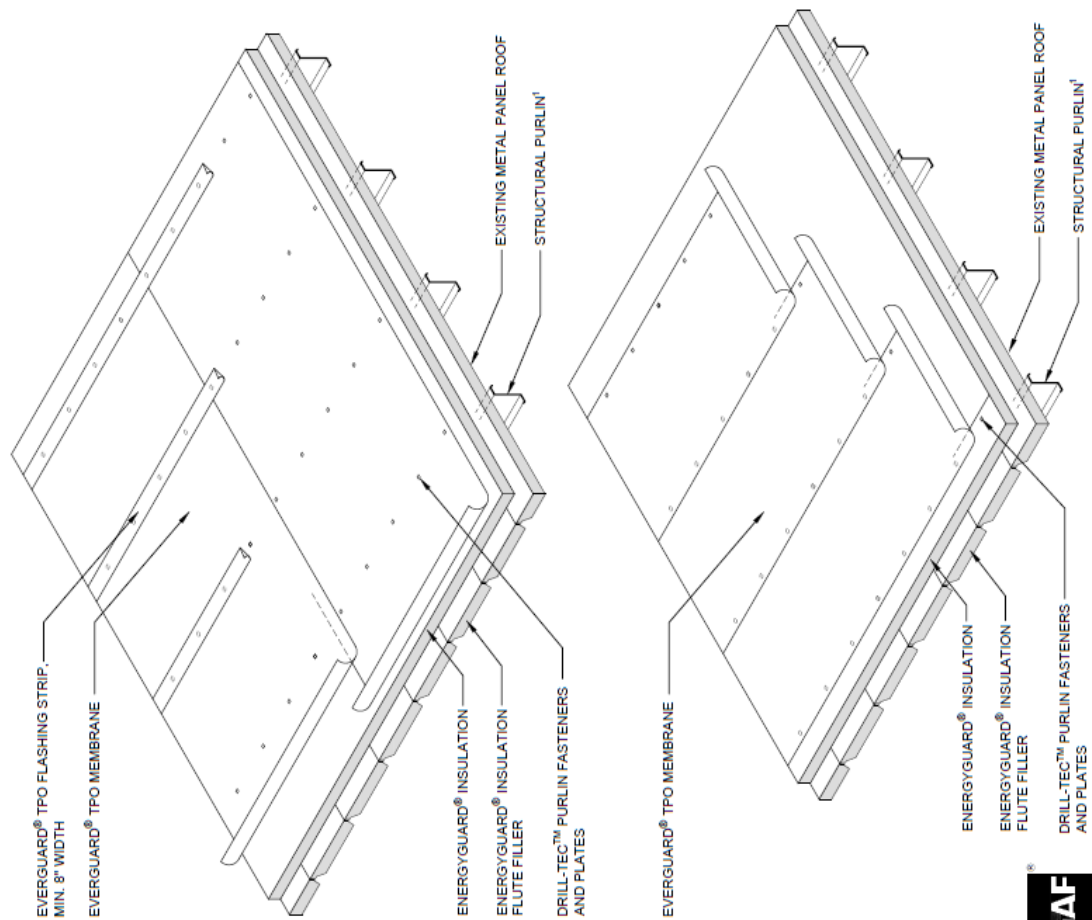

MEMBRANE TYPE
T = TPO

CONSTRUCTION TYPE
R = RECOVER

INSULATION
I = INSULATED

T MA R I 60

MEMBRANE (THICKNESS AND TYPE)	
45 =	45 MIL SMOOTH
60 =	60 MIL SMOOTH
80 =	80 MIL SMOOTH
50EX =	50 MIL EXTREME
60EX =	60 MIL EXTREME
70EX =	70 MIL EXTREME
80EX =	80 MIL EXTREME

MEMBRANE ATTACHMENT
MA = MECHANICALLY ATTACHED

MEMBRANE TYPE	MEMBRANE ATTACHMENT	CONSTRUCTION TYPE	INSULATION
T	MA	R	I
GUARANTEE LENGTH UP TO 20 YEARS			



¹ The attachment capacity of the purlins to the secondary structure must be greater than the attachment capacity of the metal panels to the purlins.

PVC MECHANICALLY ATTACHED SYSTEMS SPECIFICATION PLATE - EVERY PURLIN

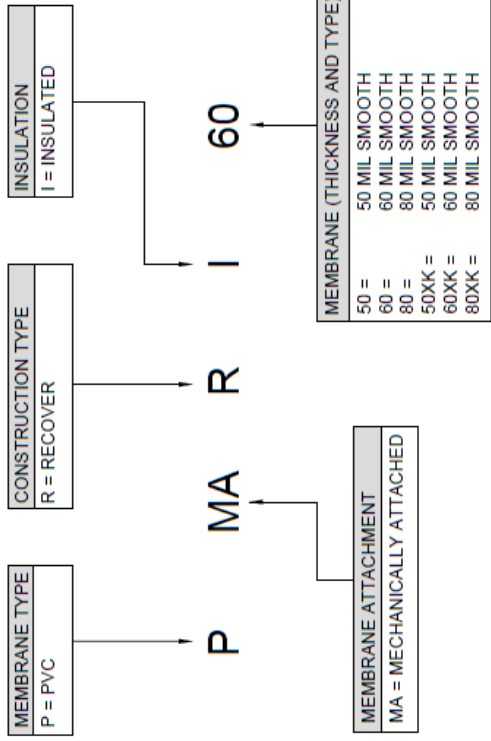
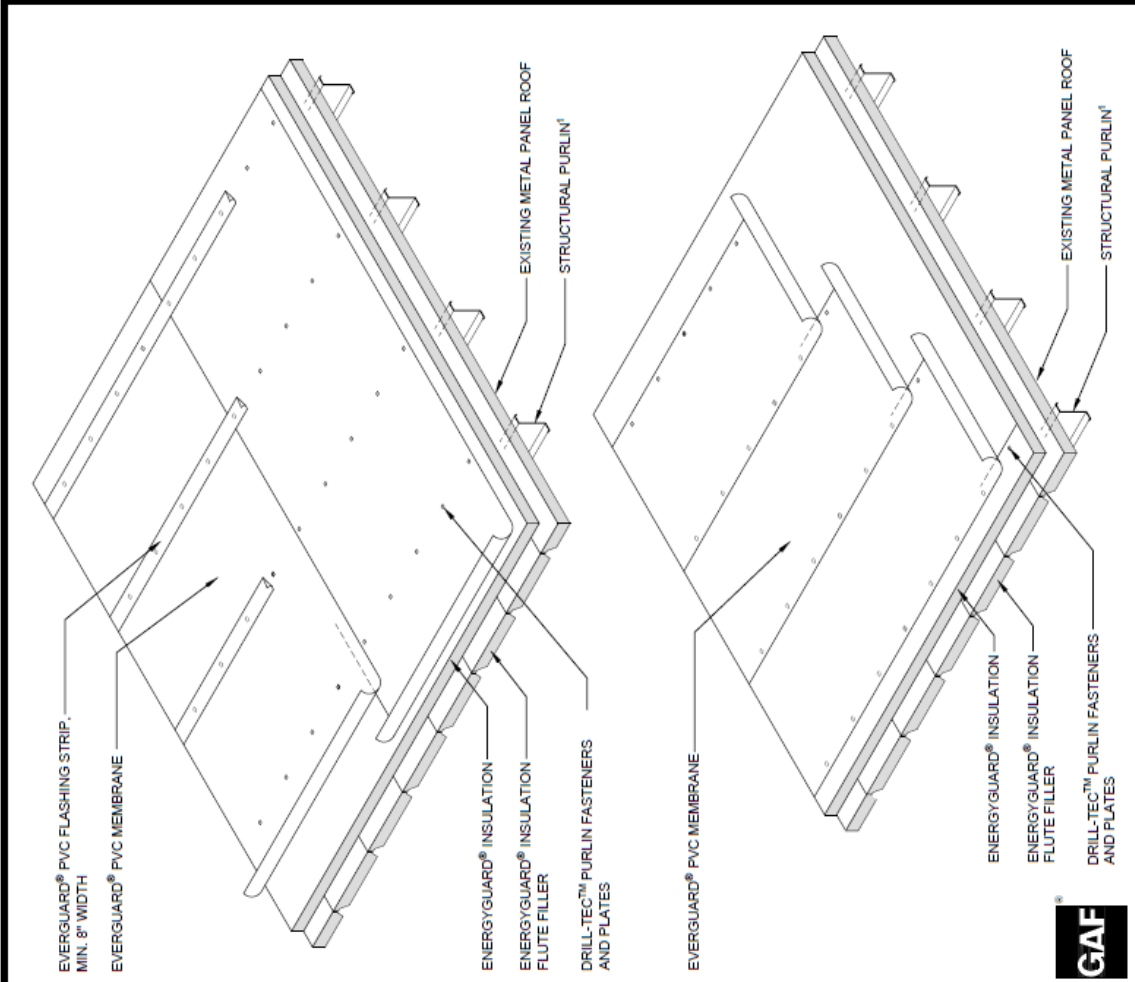

MEMBRANE TYPE	MEMBRANE ATTACHMENT	CONSTRUCTION TYPE	INSULATION
P	MA	R	I
GUARANTEE LENGTH UP TO 20 YEARS			

¹The attachment capacity of the purlins to the secondary structure must be greater than the attachment capacity of the metal panels to the purlins.

TPO MECHANICALLY ATTACHED SYSTEMS SPECIFICATION PLATE - EVERY OTHER PURLIN

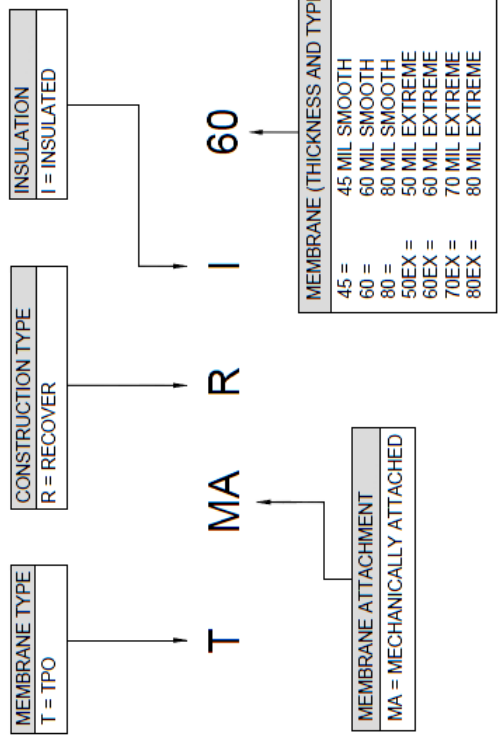
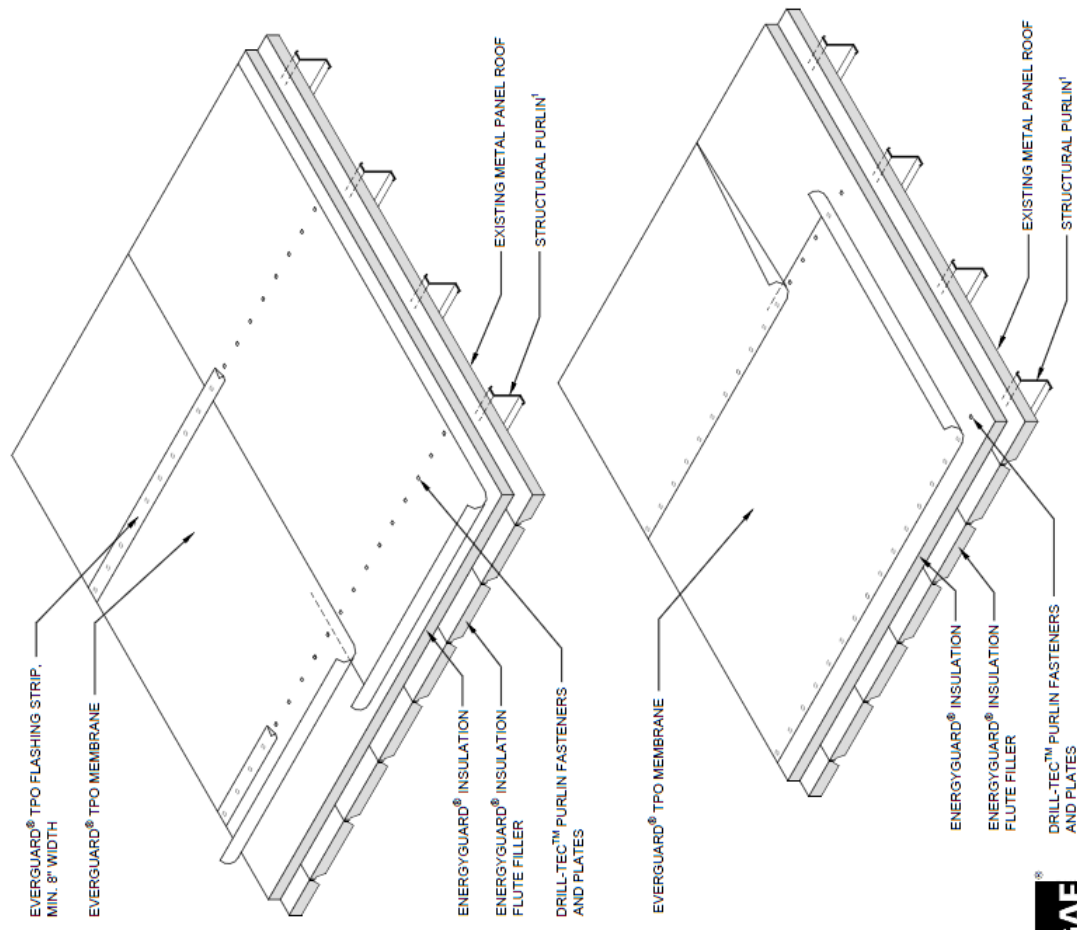

MEMBRANE TYPE	MEMBRANE ATTACHMENT	CONSTRUCTION TYPE	INSULATION
T	MA	R	I
GUARANTEE LENGTH UP TO 20 YEARS			



¹ The attachment capacity of the purlins to the secondary structure must be greater than the attachment capacity of the metal panels to the purlins.

PVC MECHANICALLY ATTACHED SYSTEMS SPECIFICATION PLATE - EVERY OTHER PURLIN

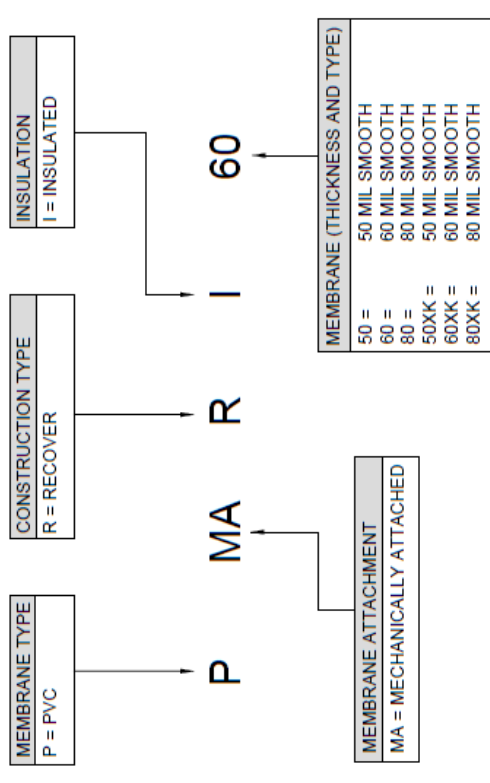
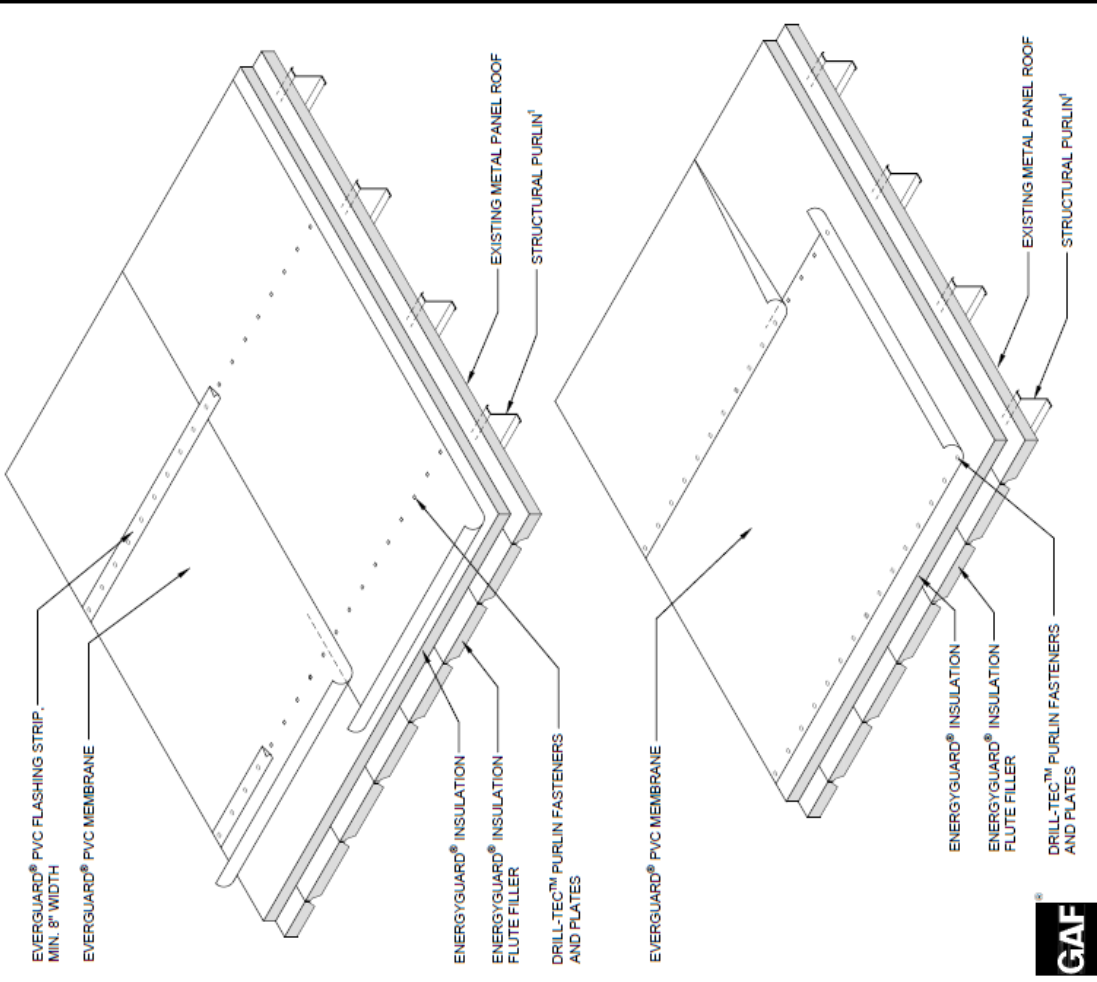

MEMBRANE TYPE	MEMBRANE ATTACHMENT	CONSTRUCTION TYPE	INSULATION
P	MA	R	I
GUARANTEE LENGTH UP TO 20 YEARS			

¹The attachment capacity of the purlins to the secondary structure must be greater than the attachment capacity of the metal panels to the purlins.

TPO DRILL-TEC™ RHINOBOND® ATTACHMENT SYSTEM SPECIFICATION PLATE

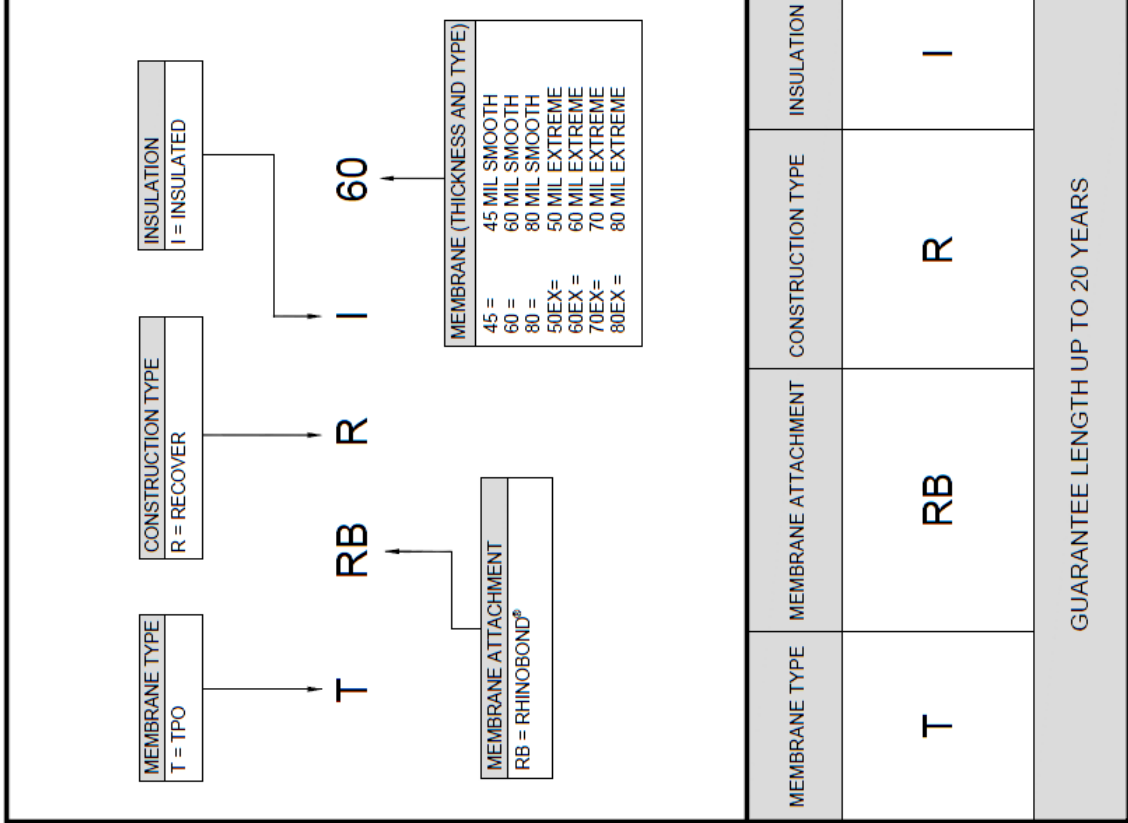

¹ The attachment capacity of the purlins to the secondary structure must be greater than the attachment capacity of the metal panels to the purlins.

PVC DRILL-TEC™ RHINOBOND® ATTACHMENT SYSTEM SPECIFICATION PLATE

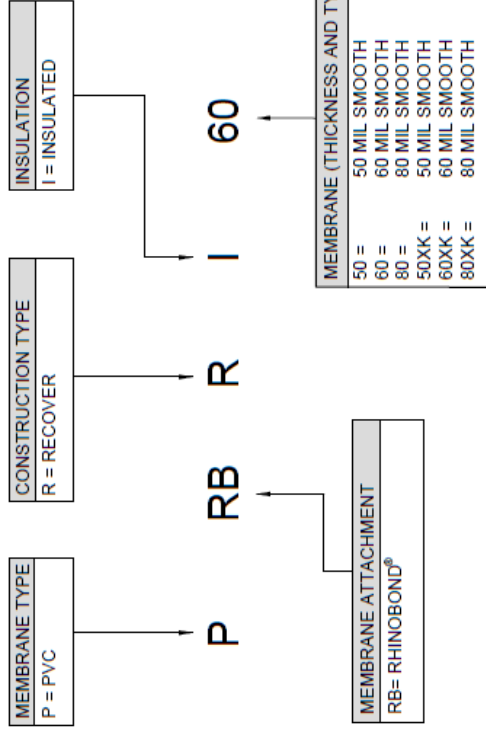
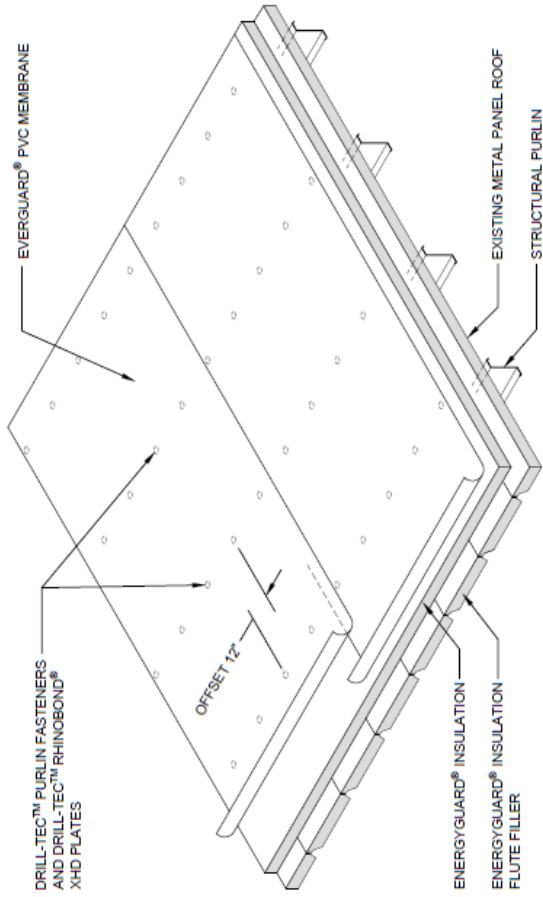

MEMBRANE TYPE	MEMBRANE ATTACHMENT	CONSTRUCTION TYPE	INSULATION
P	RB	R	I
GUARANTEE LENGTH UP TO 20 YEARS			



¹ The attachment capacity of the purlins to the secondary structure must be greater than the attachment capacity of the metal panels to the purlins.

Design Considerations & Application Guidelines

Mechanically Attached And Drill-Tec™ RhinoBond® Roofing Systems

The following are additional guidelines for roofing professionals on projects involving metal roof retrofit assemblies.

Substrate Surface Preparation & Site Conditions

1. Substrates must be inspected and accepted by the contractor as suitable to receive and hold roof membrane materials. Substrate preparation is the sole responsibility of the building owner or roofing contractor. All defects in the substrate must be corrected before roofing work commences.
2. Confirm the adequacy of the new roofing system to provide positive slope to drains. Eliminate ponding areas by the addition of drainage locations or by providing additional pitch to the roof surface.
3. Obtain verification that the building structure can accommodate the added weight of the new roofing system.
4. When staging materials on the roof during application, ensure the existing metal roof and structure are not temporarily overloaded by the weight of construction materials. Rolls of membrane, especially the 12 ft. (3.05 m) wide rolls, are exceptionally heavy.
5. The existing metal panel roof system must be free of visible moisture, such as ponding water, ice, or snow.
6. Prepare substrate surfaces thoroughly prior to application of new roofing materials. This is particularly important for re-cover and reroofing applications. Providing a smooth, even, sound, clean, and dry substrate minimizes the likelihood that underlying deficiencies will cause premature deterioration or even failure of the new roofing system.
7. Preparation includes, but is not limited to, removal of existing flashings, replacement of wet/damaged existing roofing materials, removal of loose aggregate, removal of abandoned equipment, supports and penetrations, securement and replacement of damaged and deteriorated metal decking, etc.
8. All defects in the existing metal panel roof system must be corrected before new roofing work commences. Verify that the deck surface is dry, sound, clean, and smooth, and free of depressions, waves, or projections.
9. Confirm quality and condition of existing metal panel roof system by visual inspection and by fastener pull-out testing. GAF recommends that these test results to be kept on file as part of the acceptability of the substrate surface for a Diamond Pledge™ Guarantee.
10. Remove all existing flashings and clean substrate surfaces of all adhesive contaminants. If the wall/ curb flashings are in good condition and tightly adhered to the substrate, new TPO or PVC

flashing materials may be installed over existing flashings to a height of 24" (610 mm) without adhesives.

11. Remove abandoned equipment and equipment supports.
12. Confirm that height of equipment supports will allow the installation of full-height flashings.
13. Protect building surfaces against damage and contamination from roofing work.
14. Where work must continue over completed roof areas, protect the finished roofing system from damage.

Fasteners & Plates

1. Drill-Tec™ Purlin Fasteners and plates. Refer to the appropriate Attachment Tables in this Guide for fastener spacing and pull-out requirements.
2. Drill-Tec™ RhinoBond® Fastening Plates.
3. Drill-Tec™ “flat” plates (without the countersunk screw holes protruding from the bottom of the plates) are required when plates are installed over hard surfaces such as DensDeck®, SECUROCK® or other hard cover boards to allow the plates to rest flush on the surface.
4. Drill-Tec™ XHD Fasteners and plates can be used for supplemental insulation attachment.

Installation tip: Square insulation plates, such as AccuTrac® plates, may be helpful in distinguishing them from round Drill-Tec™ RhinoBond® plates.

5. Use fasteners that are suitable for the purlin type, and ensure that purlins are of the required condition to ensure reliable installation and performance.
6. Fasteners used in flashings should be dictated by the substrate.
7. Special care should be taken when fastening plates, so as not to overdrive or underdrive the fasteners into the purlins. Overdriving the fasteners will result in a deformation or “cupping” of the plate and will result in an uneven or inadequate bond to the membrane when welded. Under-driving the fastener will result in a loose plate with insufficient clamping force and a protruding fastener head that could cause damage to the membrane during welding and through normal roof traffic.

Insulation & Flute Filler

1. The selection of insulation type, thickness, and configuration is the responsibility of the architect, engineer, owner, or roof consultant. GAF reserves the right to accept or reject any roof insulation as an acceptable substrate for GAF roof systems. GAF EnergyGuard™ insulations must be used in roofing systems for which GAF guarantees are sought. Refer to the specific EverGuard® System Manual you are working with for a complete list of approved insulation boards.

2. Flute Filler Insulation: EPS, XPS, or polyiso insulation must be used to fill in flutes of existing metal roof panels, and should fit snugly between seams of the existing metal panels. Flute filler insulation thickness should be equivalent to the height of the metal panel seams.
 - a. EnergyGuard™ Polyisocyanurate insulation with glass-based facer meeting or exceeding the requirements of ASTM C1289, min. 16 psi (110 kPa) compressive strength.
 - b. Extruded Polystyrene insulation meeting or exceeding the requirements of ASTM C578, Type II nominal 1.5 pound (42 gram/cubic cm) density and minimum 15 psi (110 kPa) compressive strength.
 - c. Expanded Polystyrene insulation with plastic facer meeting or exceeding the requirements for ASTM C578, Type II nominal 1.5 pound (42 gram/cubic cm) density and minimum 15 psi (110 kPa) compressive strength.
3. Use the minimum number of fasteners necessary to hold insulation boards in place prior to membrane attachment.

Membrane Installation – Mechanically Attached Roofing System into Purlins

Membrane Placement

1. Place roof membrane so that wrinkles and buckles are not formed. Remove any wrinkles or buckles from the sheet prior to permanent securement. Roof membrane must be mechanically fastened after it is rolled out, followed by welding to adjacent sheets.
2. Overlap roof membrane a minimum of 6" (152 mm) for side laps of mechanically attached systems, and a minimum of 3" (76 mm) for end laps. Membranes are provided with lap lines along the side laps; the inside line is for mechanically attached system overlaps, which are 6" (152 mm) for TPO membranes. For PVC membranes, the solid line (overlap line) is marked on the top ply 5" (127 mm) from the sheet edge. The fastener line is a nominal 2" (51 mm) from the sheet edge, and an "X" is placed between the sheet edge and the field seam overlap line with spacing every 6" (152 mm). TPO fastener spacing marks should resemble a "pyramid" pattern.
3. Best practice is to install membrane so that the flow of water is parallel or over the side laps toward drainage points.

Membrane Securement

1. The Mechanically Attached Metal Retrofit System secures the membrane by mechanically fastening into purlins with Drill-Tec™ Purlin Fasteners as required by the Attachment Tables in this Guide. The fasteners are installed into the purlins for maximum uplift resistance.
2. Depending on sheet orientation and placement of the fasteners into the purlins, fasteners may be located in the seams of the membrane or in the field of the sheet. Fasteners not located in the seams should be covered by an 8" (203 mm) wide flashing strip hot air welded to the membrane.
3. Fasteners must be installed to achieve the proper embedment depth. Install fasteners vertical to the substrate/deck, without lean or tilt. Do not over- or under-drive fasteners. Install fasteners so that the plate is drawn down tightly to the membrane surface. Properly installed fasteners

will not allow the plate to move (underdriving), but will not cause wrinkling of the membrane (overdriving).

4. Fastener pullout tests shall be conducted on the purlins with approved fasteners. Refer to the TPO & PVC Attachment Table for Mechanically Attached Systems in the Guide for complete requirements.
5. Membrane may be heat-welded to EverGuard® coated metal flanges.
6. Membrane must be secured to the substrate within 6" (152 mm) of the base of walls and curbs, at the perimeter and at all penetrations with Drill-Tec™ XHD Fasteners and barbed plates with a 12" (305 mm) o.c. maximum spacing.

Alternatively, membrane may be extended vertically 3" up walls and curbs and secured to the wall/curb substrate within 2" (51 mm) of the plane of the roof. Use Drill-Tec™ XHD Fasteners and inverted termination bar of type and spacing in accordance with in-lap attachment requirements, with a 12" (305 mm) o.c. maximum spacing. Vertical attachment with seam plates and fasteners may also be used. This alternative detail, including termination bar, is required to be used for pressurized buildings.

Membrane Installation – Drill-Tec™ RhinoBond® Roofing System into Purlins

Membrane Placement

1. Place roof membrane so that wrinkles and buckles are not formed. Remove any wrinkles or buckles from the sheet prior to permanent securement.
2. Full-width rolls can be installed throughout the field and perimeter of the roof. Half sheets are not necessary.
3. Overlap roof membrane a minimum of 3" (76 mm) for end laps of EverGuard® PVC and TPO membranes. Membranes are provided with lap lines along the side laps; the red line is for the Drill-Tec™ RhinoBond® Attachment System. PVC does not have an adhered line.
4. Best practice is to install membrane so that the flow of water is parallel or over the side laps toward drainage points

Membrane Securement

1. The RhinoBond® Purlin Attachment Metal Retrofit System secures the membrane to the purlins without penetrating the roofing material.
2. The Drill-Tec™ Purlin Fasteners are installed into the purlins for maximum uplift resistance without being placed in the seams of the membrane. Once the fasteners are in place, unroll the membrane and weld the membrane to the specially coated RhinoBond® plates using the Drill-Tec™ RhinoBond® induction welding tool. Then, hot air weld the membrane seams.

3. Fastener pullout tests shall be conducted on the purlins with approved fasteners. Refer to the TPO & PVC Attachment Table for Drill-Tec™ RhinoBond® Systems in the Guide for complete requirements.
4. Since fastening patterns are different in the field, perimeter and corner areas, treat each as a separate zone and weld each zone separately. This helps ensure that all plates are welded as you move from zone to zone. Refer to the TPO & PVC Attachment Table for Drill-Tec™ RhinoBond® Attached Systems in this Guide.
5. Roof membrane must be mechanically secured at the perimeter, at the base of internal walls and curbs, and at all penetrations with Drill-Tec™ RhinoBond® Plates and XHD Fasteners at 12" (305 mm) o.c. maximum spacing. Membrane may be heat-welded to coated metal flanges. A minimum of 4 fasteners per penetration is required. Note: This assembly must be placed no closer than 4.5" (113 mm) from vertical flashings and a maximum of 6" (152 mm) away to facilitate the proper placement of the RhinoBond® induction welder. Specific details are available for these conditions in this Guide. Alternatively, standard mechanical base attachment can be used 12" (305 mm) o.c.
6. Fasteners must be installed to achieve the proper embedment depth. Install fasteners vertical to the substrate/deck, without lean or tilt. Do not overdrive or underdrive fasteners. Install fasteners so that the plate is drawn down tightly to the substrate surface.

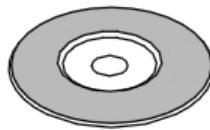
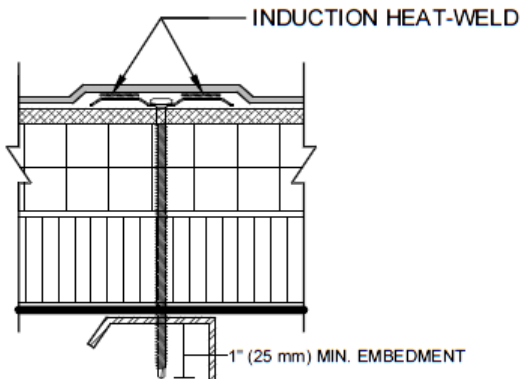

DRILL-TEC™ RHINOBOND® XHD PLATE



DRILL-TEC™ PURLIN FASTENER

NOTE:

TPO= YELLOW PLATE
PVC= BLACK PLATE

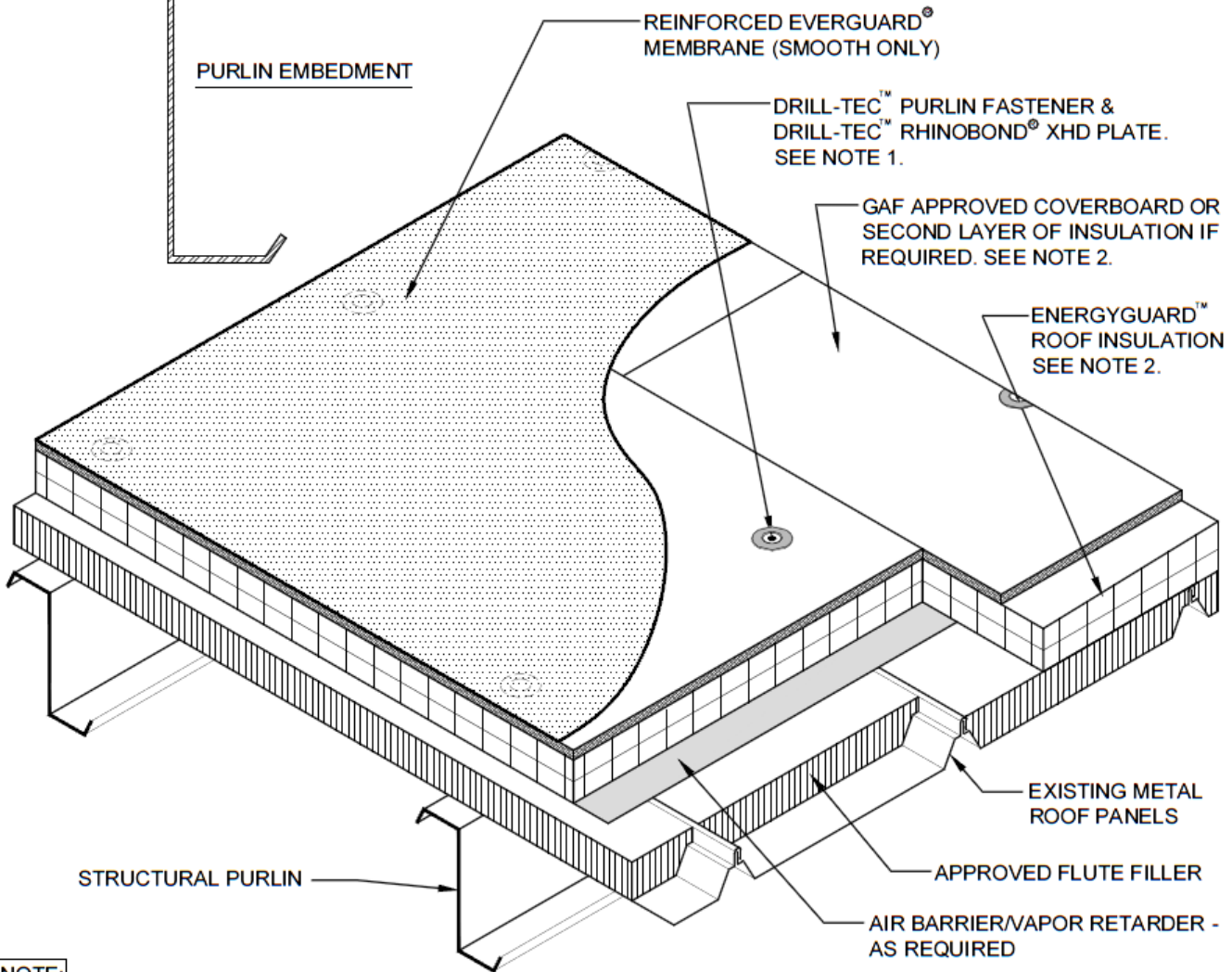

NOTE:

1. REFER TO THE DRILL-TEC™ RHINOBOND® PURLIN ATTACHMENT TABLE FOR ADDITIONAL INFORMATION.
2. USE MINIMUM NUMBER OF FASTENERS NECESSARY TO HOLD INSULATION BOARDS IN PLACE PRIOR TO MEMBRANE ATTACHMENT.



www.gaf.com
1 Campus Drive
Parsippany, NJ 07054

EverGuard
ROOF PENETRATION SERIES

METAL RETROFIT

DRAWING #

100F

SCALE

N.T.S.

DRILL-TEC™ RHINOBOND® ASSEMBLY PURLIN DETAIL

THIS DETAIL APPLIES TO
Plate-Welded Systems

REVISION DATE

3-11-19

Published 12/2020

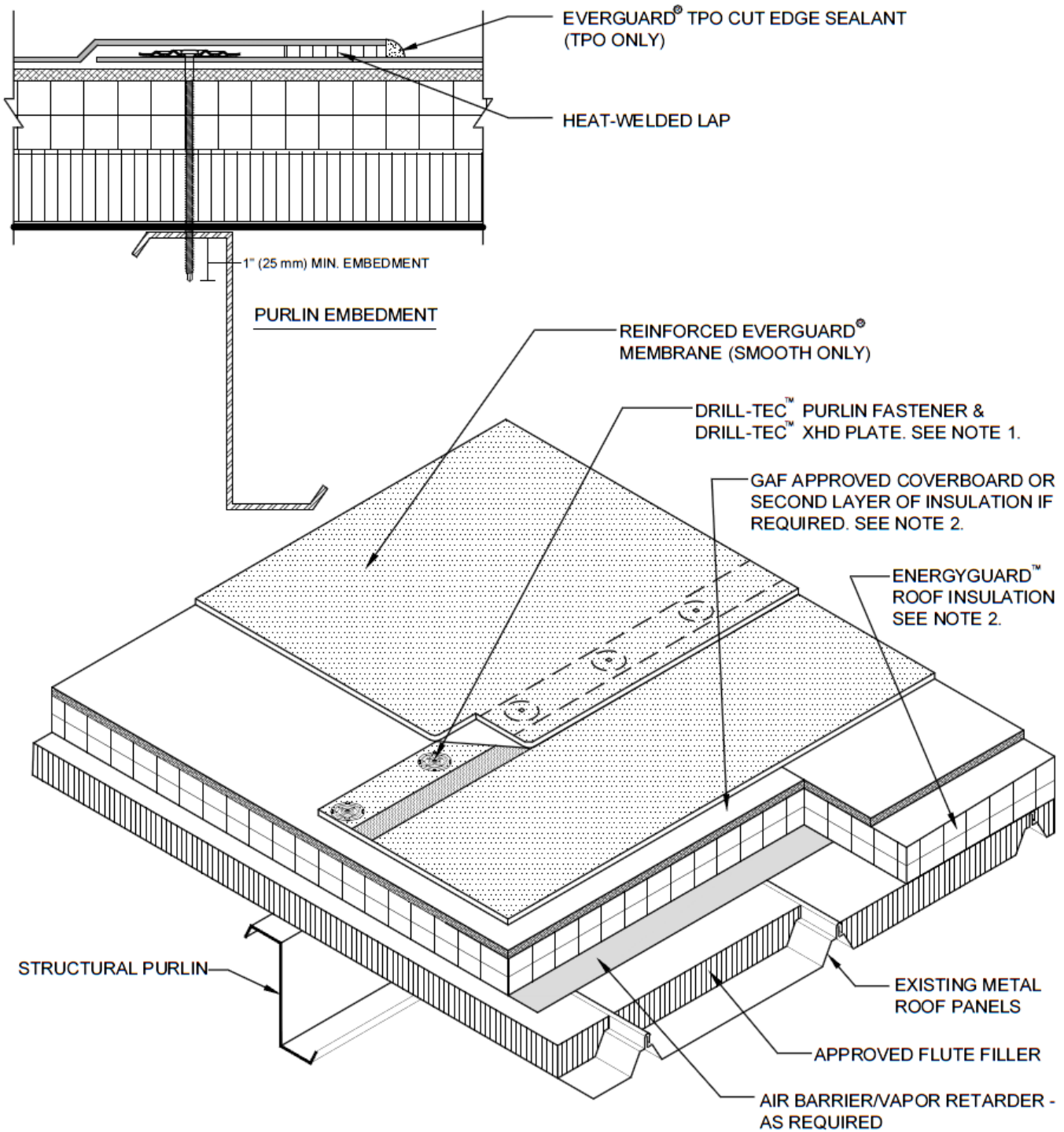

EverGuard® Metal Retrofit



NOTE:



1. REFER TO THE MECHANICALLY PURLIN ATTACHED SYSTEMS TABLE FOR ADDITIONAL INFORMATION.
2. USE MINIMUM NUMBER OF FASTENERS NECESSARY TO HOLD INSULATION BOARDS IN PLACE PRIOR TO MEMBRANE ATTACHMENT.

EverGuard® Metal Retrofit Published 12/2020

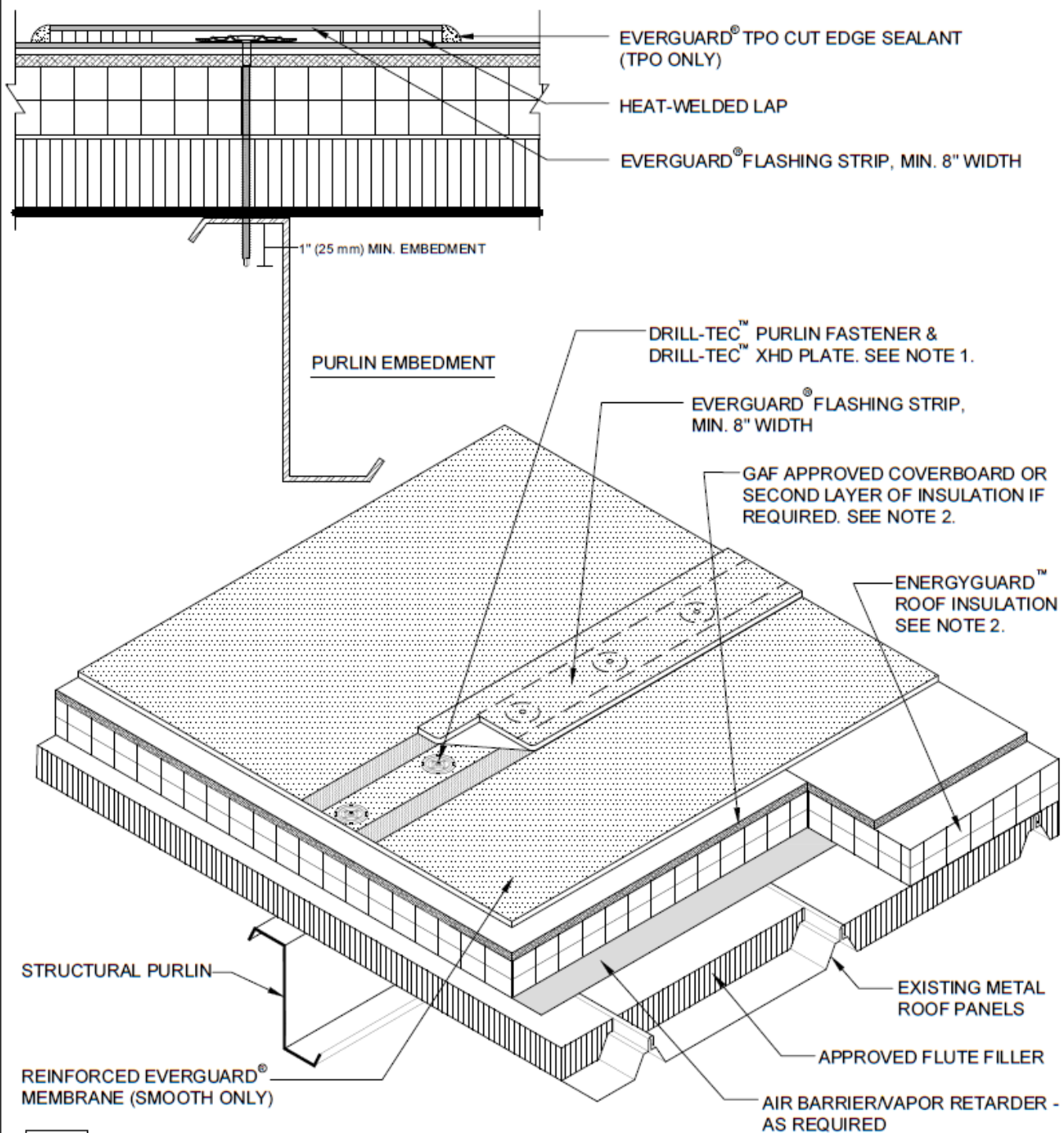
 <small>www.gaf.com</small> <small>1 Campus Drive Parsippany, NJ 07054</small>	 ROOF PENETRATION SERIES	DRAWING# 100G	MECHANICALLY ATTACHED ASSEMBLY PURLIN DETAIL - FASTENERS LOCATED IN SEAMS	THIS DETAIL APPLIES TO Mechanically-Attached Systems
	METAL RETROFIT	SCALE N.T.S.		REVISION DATE 3-11-19



- NOTE:**
1. REFER TO THE MECHANICALLY PURLIN ATTACHED SYSTEMS TABLE FOR ADDITIONAL INFORMATION.
 2. USE MINIMUM NUMBER OF FASTENERS NECESSARY TO HOLD INSULATION BOARDS IN PLACE PRIOR TO MEMBRANE ATTACHMENT.

 <small>www.gaf.com 1 Campus Drive Parsippany, NJ 07054</small>	 ROOF PENETRATION SERIES	DRAWING # 100H	MECHANICALLY ATTACHED ASSEMBLY PURLIN DETAIL - FASTENERS STRIPPED IN	THIS DETAIL APPLIES TO: Mechanically-Attached Systems
	METAL RETROFIT	SCALE N.T.S.		REVISION DATE 3-11-19

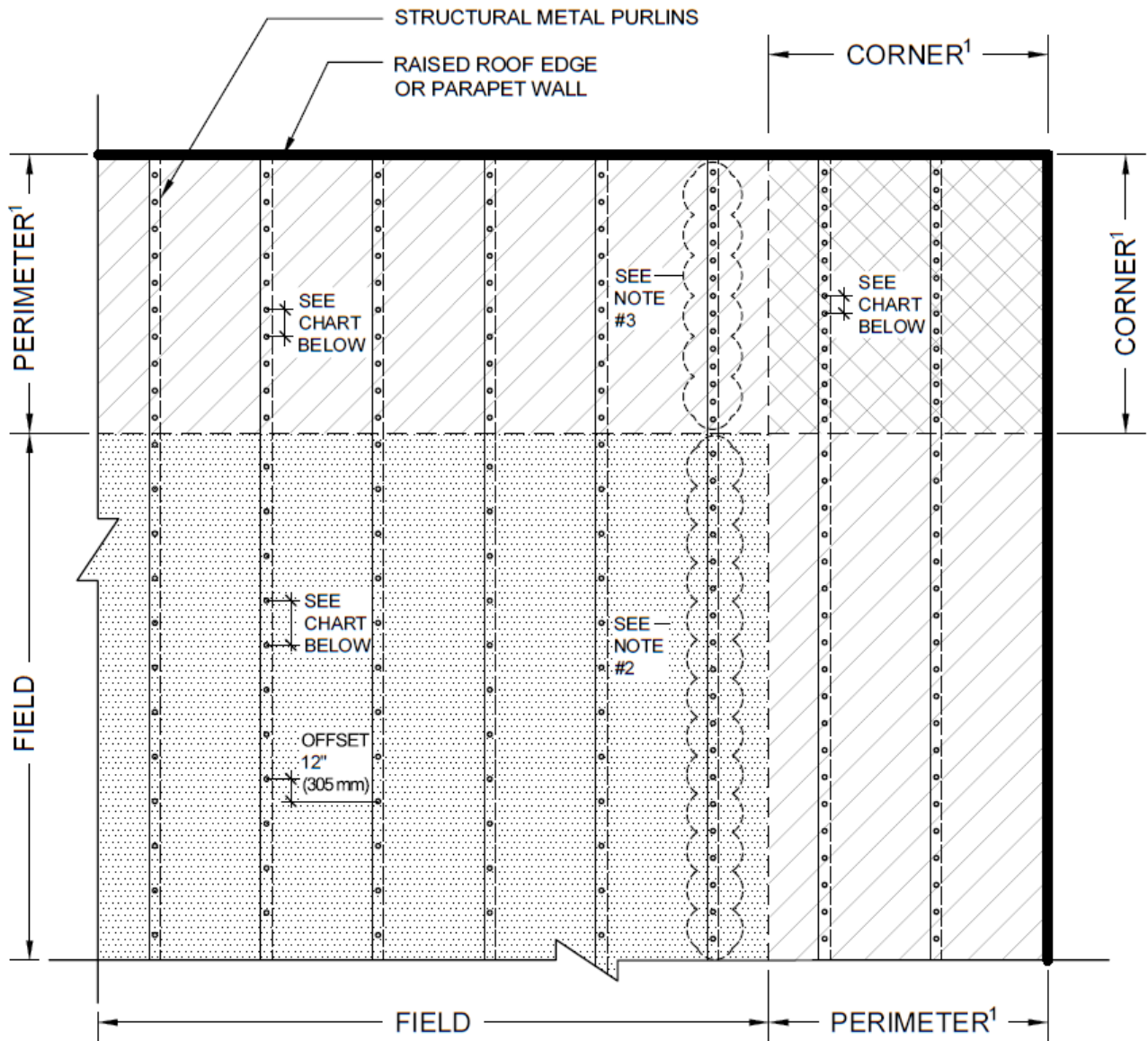

MAXIMUM FASTENER SPACING			
PURLIN TYPE	FIELD ZONE	PERIMETER ZONE	CORNER ZONE
MIN. 16 GA.	24" O.C.	10" O.C.	8" O.C.
MIN. 14 GA.	24" O.C.	12" O.C.	9" O.C.
MIN. 12 GA.	24" O.C.	12" O.C.	9" O.C.

ZONE LEGEND	
	FIELD
	PERIMETER
	CORNER

NOTE:

1. SEE EVERGUARD® SYSTEM GUIDELINES IN SPEC MANUAL TO DETERMINE PERIMETER AND CORNER ZONES.
2. DEFAULTS TO PERIMETER FASTENING RATE.
3. DEFAULTS TO CORNER FASTENING RATE.

Published 12/2020

EverGuard® Metal Retrofit

 www.gaf.com 1 Campus Drive, Parsippany, NJ 07054	 FIELD OF ROOF SERIES	DRAWING# 101F	PURLIN FASTENING ZONES - DRILL-TEC™ RHINOBOND® ASSEMBLY	THIS DETAIL APPLIES TO: Plate-Welded Systems
	METAL RETROFIT	SCALE N.T.S.		REVISION DATE 3-11-19

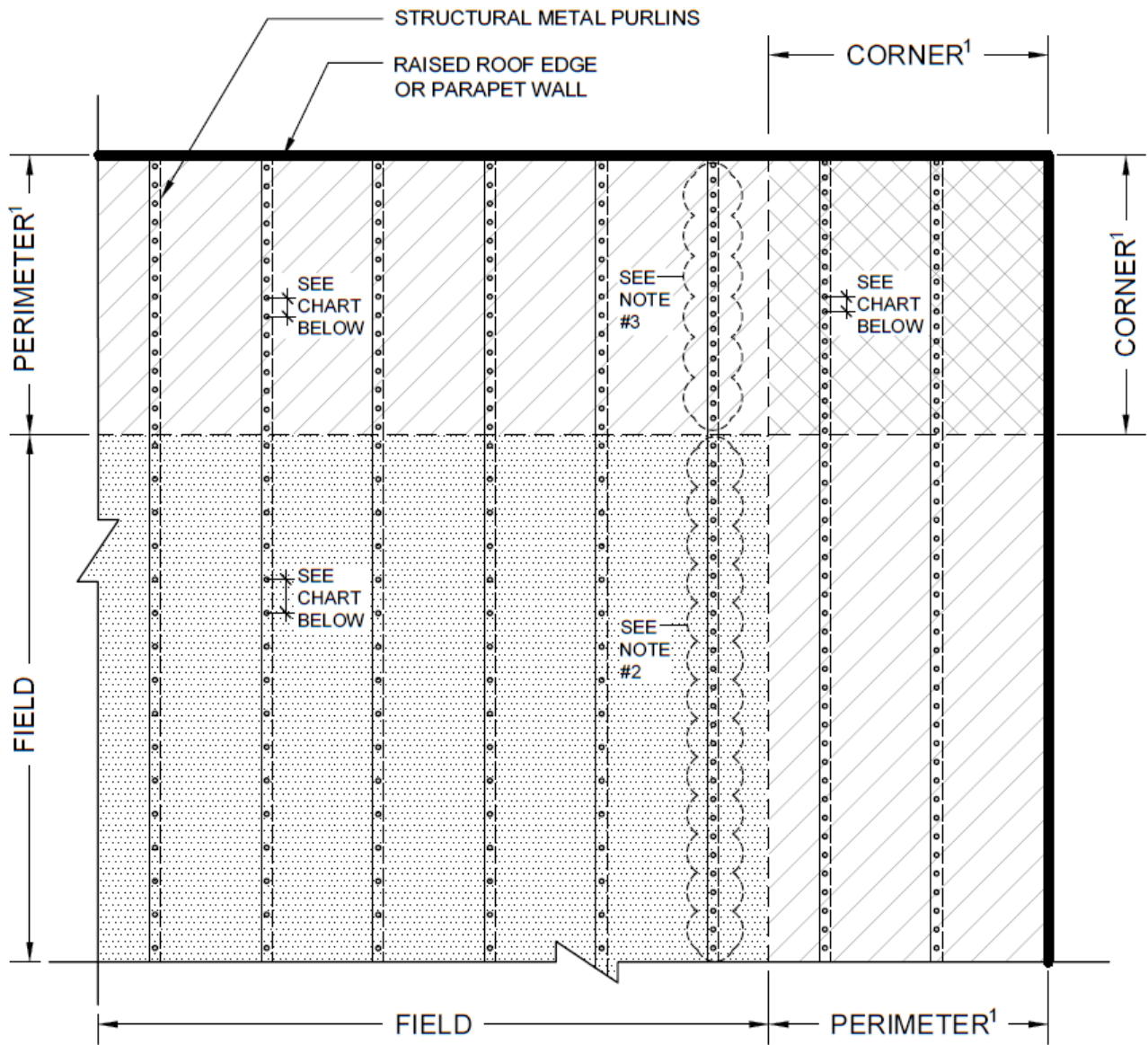

MAXIMUM FASTENER SPACING			
PURLIN TYPE	FIELD ZONE	PERIMETER ZONE	CORNER ZONE
MIN. 16 GA.	12" O.C.	10" O.C.	8" O.C.
MIN. 14 GA.	18" O.C.	12" O.C.	9" O.C.
MIN. 12 GA.	18" O.C.	12" O.C.	9" O.C.

ZONE LEGEND	
	FIELD
	PERIMETER
	CORNER

NOTE:

1. SEE EVERGUARD® SYSTEM GUIDELINES IN SPEC MANUAL TO DETERMINE PERIMETER AND CORNER ZONES.
2. DEFAULTS TO PERIMETER FASTENING RATE.
3. DEFAULTS TO CORNER FASTENING RATE.

 www.gaf.com 1 Campus Drive, Parsippany, NJ 07054	 FIELD OF ROOF SERIES	DRAWING# 101G	PURLIN FASTENING ZONES - MECHANICALLY ATTACHED ASSEMBLY EVERY PURLIN	THIS DETAIL APPLIES TO Mechanically Attached Systems
	METAL RETROFIT	SCALE N.T.S.		REVISION DATE 3-11-19

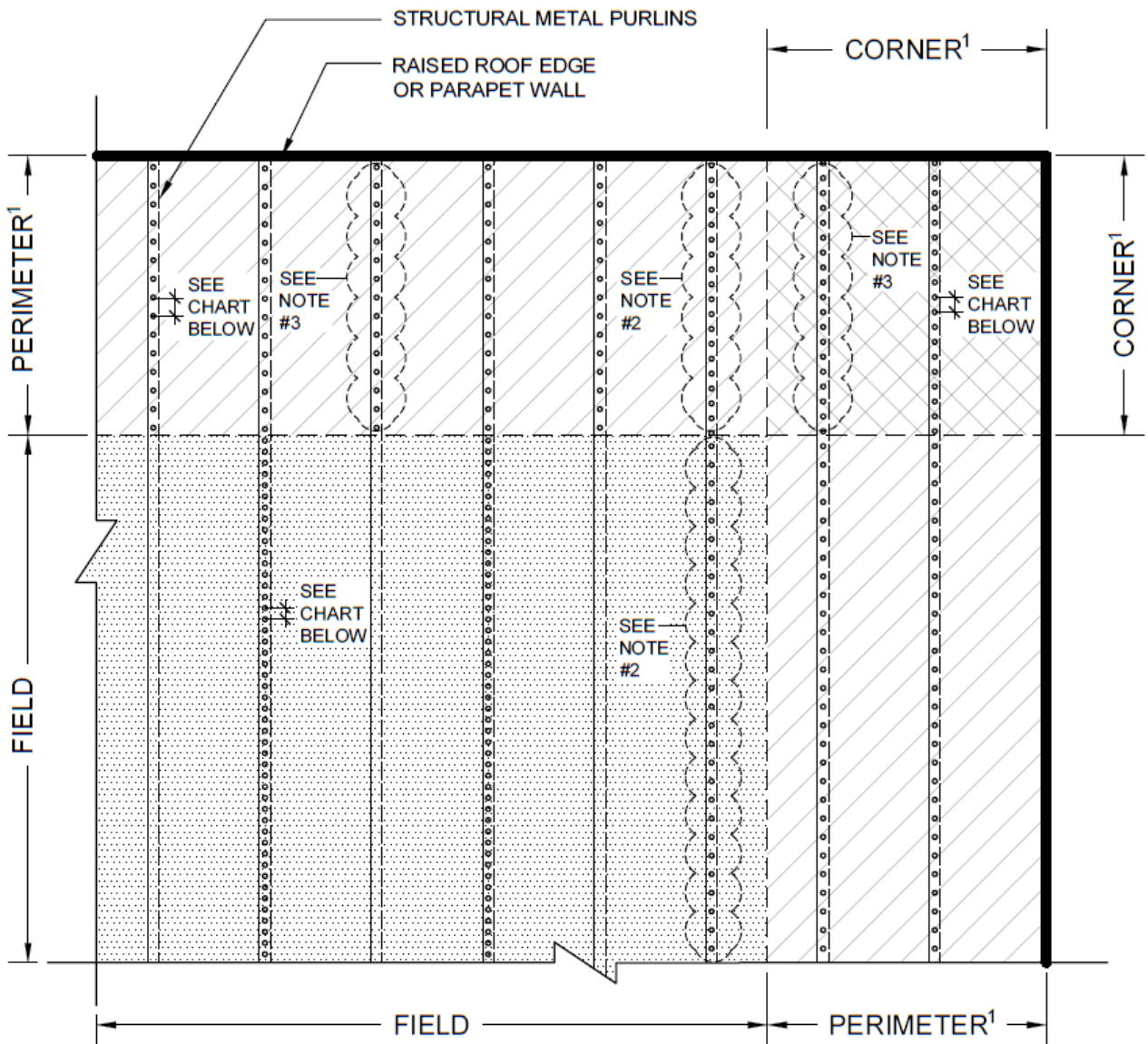

MAXIMUM FASTENER SPACING			
PURLIN TYPE	FIELD ZONE	PERIMETER ZONE	CORNER ZONE
MIN. 16 GA.	6" O.C.	10" O.C.	8" O.C.
MIN. 14 GA.	9" O.C.	12" O.C.	9" O.C.
MIN. 12 GA.	9" O.C.	12" O.C.	9" O.C.

ZONE LEGEND	
	FIELD
	PERIMETER
	CORNER

NOTE:

1. SEE EVERGUARD[®] SYSTEM GUIDELINES IN SPEC MANUAL TO DETERMINE PERIMETER, AND CORNER ZONES.
2. INSTALL FASTENERS INTO PURLINS ADJACENT TO PERIMETER AND CORNER ZONES.
3. INSTALL FASTENERS INTO EVERY PURLIN IN PERIMETER AND CORNER ZONES.

 www.gaf.com 1 Campus Drive, Parsippany, NJ 07054	 FIELD OF ROOF SERIES	DRAWING# 101H	PURLIN FASTENING ZONES - MECHANICALLY ATTACHED ASSEMBLY EVERY OTHER PURLIN	THIS DETAIL APPLIES TO: Mechanically Attached Systems
	METAL RETROFIT	SCALE N.T.S.		REVISION DATE 3-11-19

Published 12/2020

EverGuard[®] Metal Retrofit

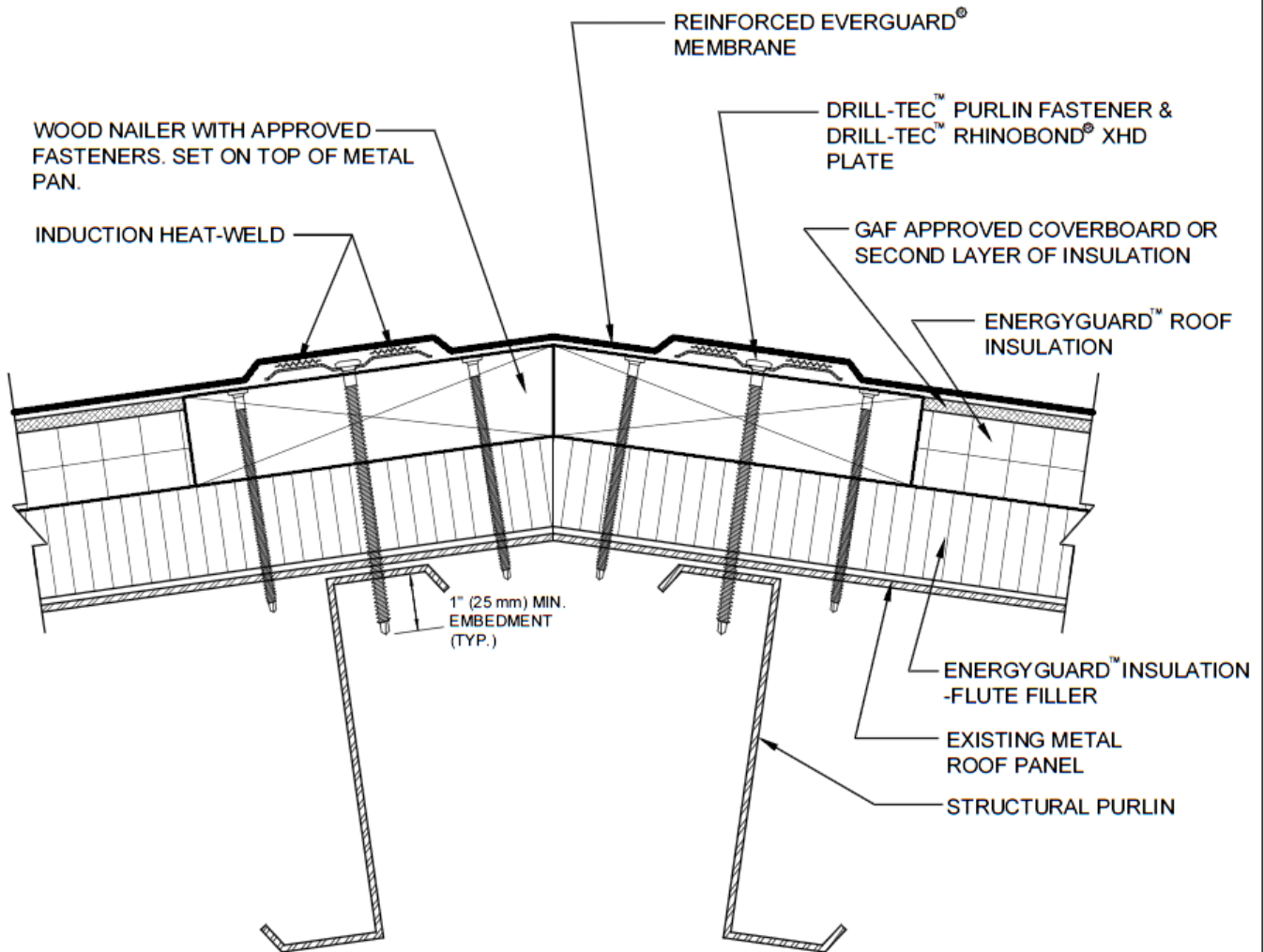

NOTE:

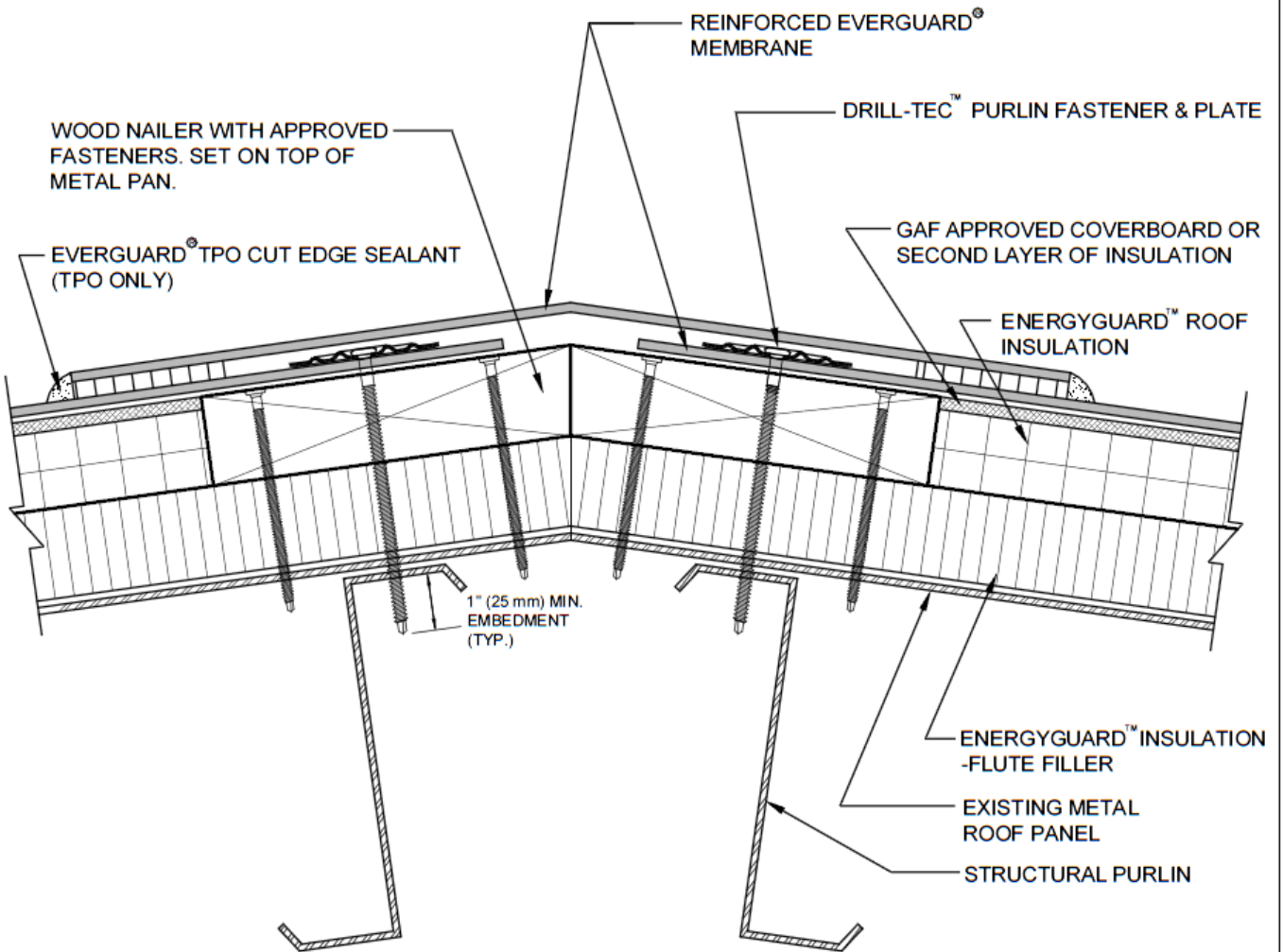

1. REFER TO THE DRILL-TEC™ RHINOBOND® PURLIN ATTACHED SYSTEMS TABLE FOR DETAILED INSTALLATION REQUIREMENTS.

 www.gaf.com 1 Campus Drive Parsippany, NJ 07054	 FIELD OF ROOF SERIES	DRAWING # 110F	METAL ROOF RIDGE DETAIL DRILL-TEC™ RHINOBOND® ASSEMBLY	THIS DETAIL APPLIES TO Plate-Welded Systems
	METAL RETROFIT	SCALE N.T.S.		REVISION DATE 3-11-19



NOTE:

1. REFER TO THE MECHANICALLY PURLIN ATTACHED SYSTEMS TABLE FOR DETAILED INSTALLATION REQUIREMENTS.

 www.gaf.com 1 Campus Drive Parsippany, NJ 07054	 FIELD OF ROOF SERIES	DRAWING# 110G	METAL ROOF RIDGE DETAIL MECHANICALLY ATTACHED ASSEMBLY	THIS DETAIL APPLIES TO Mechanically Attached Systems
	METAL RETROFIT	SCALE N.T.S.		REVISION DATE 3-11-19

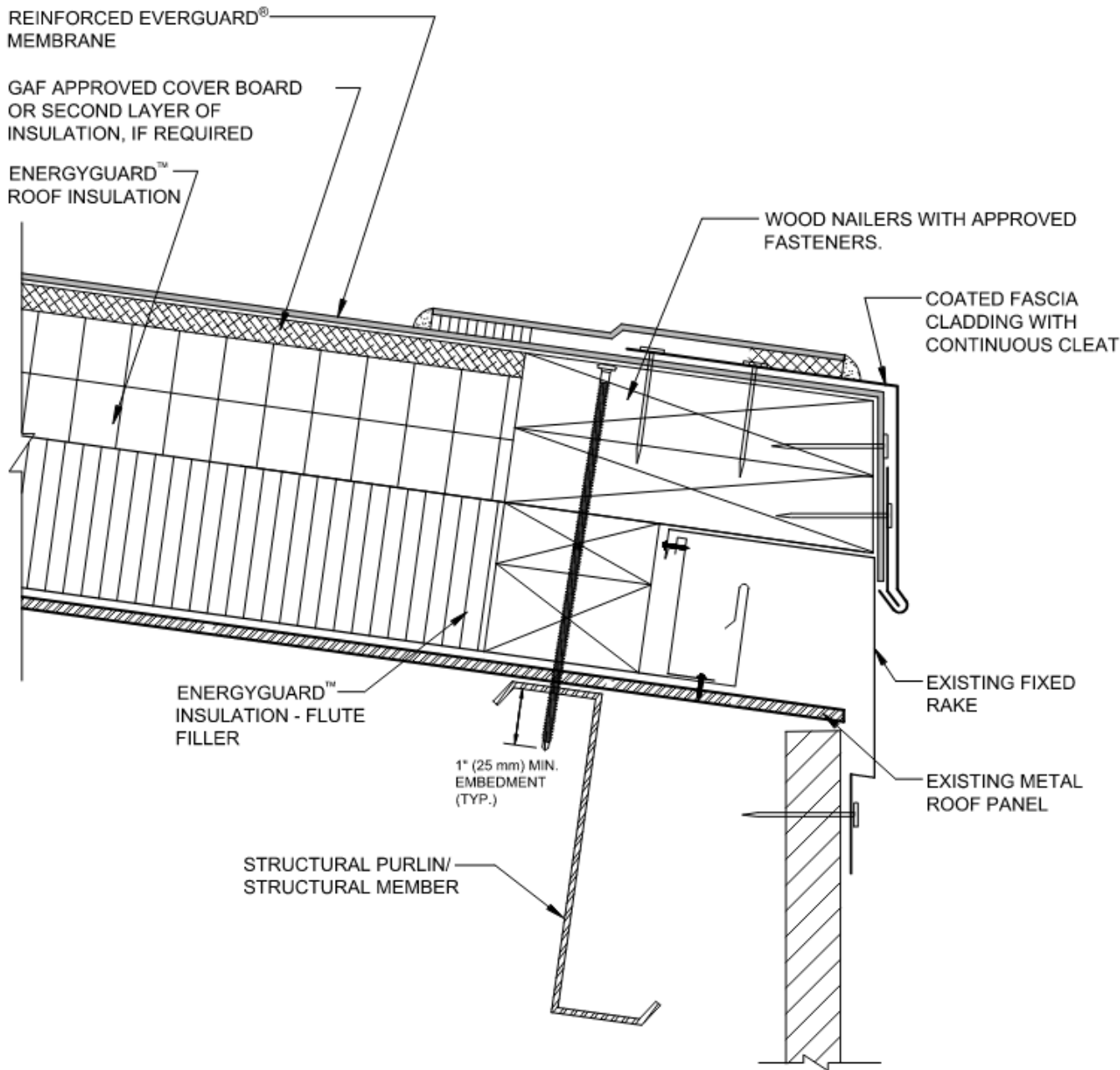

NOTE:

1. REFER TO THE MECHANICALLY PURLIN ATTACHMENT TABLE FOR ADDITIONAL INFORMATION.
2. USE STRIPPING DETAIL APPROPRIATE TO THE MEMBRANE, METAL TYPE AND GUARANTEE PERIOD. REFER TO EVERGUARD® 200 SERIES DETAILS.
3. CLEAN METAL AND MEMBRANE WITH EVERGUARD® TPO SEAM CLEANER AND ALLOW TO DRY. ONCE DRY, PRIME METAL AND MEMBRANE WITH EVERGUARD® TPO PRIMER BEFORE INSTALLING EVERGUARD® TPO COVER TAPE.

 www.gaf.com 1 Campus Drive, Parsippany, NJ 07054	 ROOF EDGE SERIES	DRAWING # 202H	METAL ROOF EDGE DETAIL - FIXED RAKE EDGE	THIS DETAIL APPLIES TO: RhinoBond Systems Mechanically Attached Systems
	METAL RETROFIT	SCALE N.T.S.		REVISION DATE 1-10-20

REINFORCED EVERGUARD®
MEMBRANE

GAF APPROVED COVER BOARD
OR SECOND LAYER OF
INSULATION, IF REQUIRED

ENERGYGUARD™
ROOF INSULATION

WOOD NAILERS WITH APPROVED
FASTENERS.

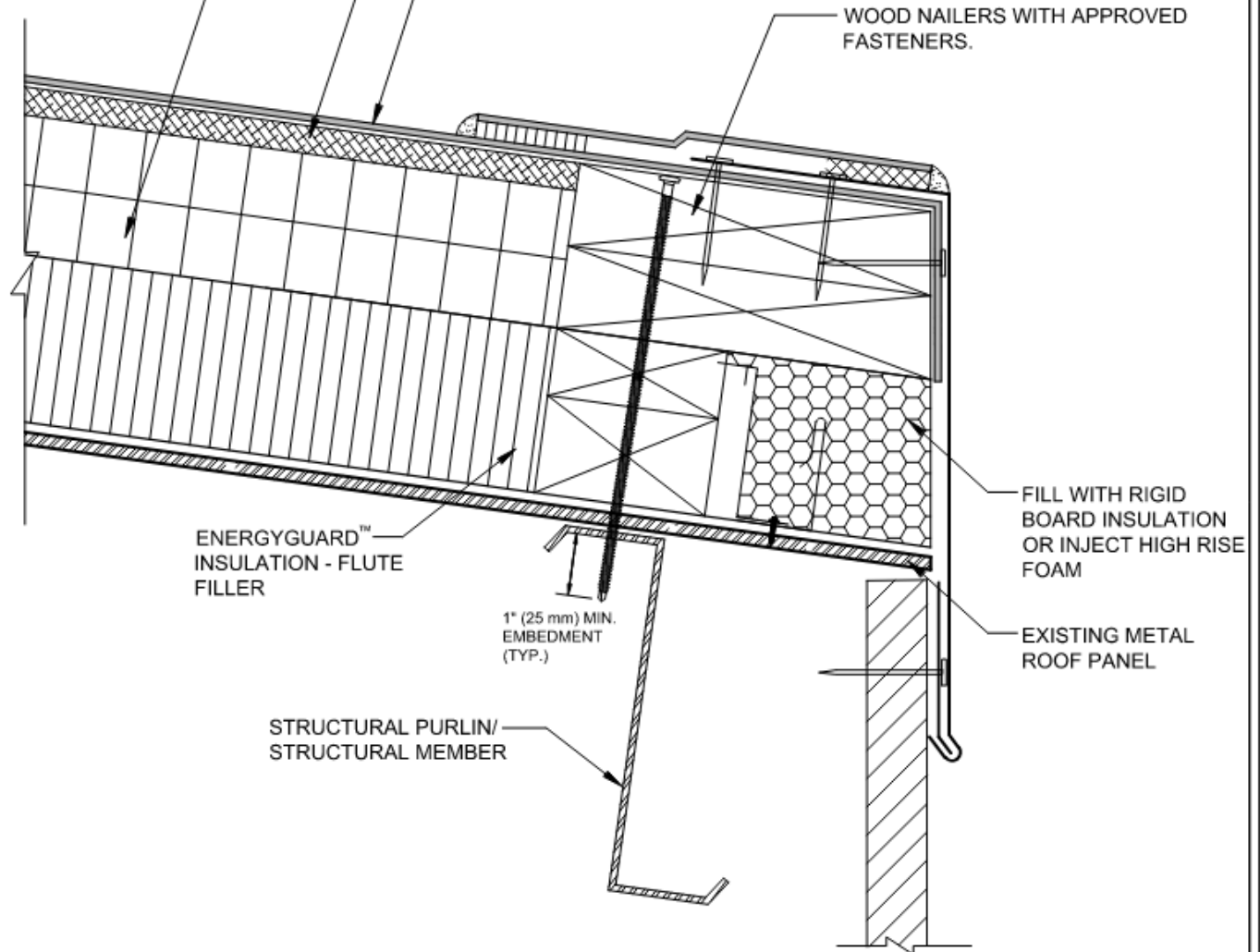

FILL WITH RIGID
BOARD INSULATION
OR INJECT HIGH RISE
FOAM

EXISTING METAL
ROOF PANEL

ENERGYGUARD™
INSULATION - FLUTE
FILLER

1" (25 mm) MIN.
EMBEDMENT
(TYP.)

STRUCTURAL PURLIN/
STRUCTURAL MEMBER

NOTE:

1. REFER TO THE MECHANICALLY PURLIN ATTACHMENT TABLE FOR ADDITIONAL INFORMATION.
2. USE STRIPPING DETAIL APPROPRIATE TO THE MEMBRANE, METAL TYPE AND GUARANTEE PERIOD. REFER TO EVERGUARD® 200 SERIES DETAILS.
3. REMOVE EXISTING FLOATING RAKE AND CLIP.
4. CLEAN METAL AND MEMBRANE WITH EVERGUARD® TPO SEAM CLEANER AND ALLOW TO DRY. ONCE DRY, PRIME METAL AND MEMBRANE WITH EVERGUARD® TPO PRIMER BEFORE INSTALLING EVERGUARD® TPO COVER TAPE.

Published 12/2020

EverGuard® Metal Retrofit



EverGuard
MULTI-PLY ROOFING SYSTEMS
ROOF EDGE SERIES

DRAWING #
2021

**METAL ROOF EDGE DETAIL
- FLOATING RAKE EDGE**

THIS DETAIL APPLIES TO:
RhinoBond Systems
Mechanically Attached Systems

www.gaf.com
1 Campus Drive,
Parsippany, NJ 07054

METAL RETROFIT

SCALE
N.T.S.

REVISION DATE
1-10-20

Appendix A: Design Parameters

The fastener spacings presented in this guide were calculated using the Allowable Stress Design method from the 2010 edition of ASCE 7, “Minimum Design Loads and Associated Criteria for Buildings and Other Structures,” and based on an example building with the following design parameters:

- Maximum building height = 40 ft.
- Basic wind speed = 120 mph
- Exposure Category = Exposure C
- Building Risk Category = Risk Category II
- Enclosure Classification = Partially Enclosed
- Maximum roof slope = 2:12

GAF recommends a licensed design professional calculate fastener spacings using design parameters applicable to the specific building.

Example Fastener Spacing Guide for TPO/PVC Mechanically Attached Retrofit Roofing Systems

Roof Zone	Design Uplift ¹ (psf)	Fastener Spacing on center ³ (inches)		
		Steel Purlin Gage Thickness		
		16	14	12
Field of Roof	62	12 ⁴ 6 ⁵	18 ⁴ 9 ⁵	18 ⁴ 9 ⁵
Perimeter ²	97	10	12	12
Corner ²	133	8	9	9

1. Factor of Safety of 2.0 included.
2. If half sheets are used, corner and perimeter may need up to three half sheets at 5 ft. each, depending on building geometry (licensed design professional to calculate number of half sheets needed).
3. Allowable fastener load per TPO/PVC attachment tables; minimum pullout (lbs/fastener).
4. Spacing for fastening roof membrane to every purlin; maximum 5 ft. apart.
5. Spacing for fastening roof membrane to every other purlin; maximum 10 ft. apart.

Appendix B: Alternative Design Parameters

The fastener spacings presented below were calculated using the Allowable Stress Design method from the 2010 edition of ASCE 7, "Minimum Design Loads and Associated Criteria for Buildings and Other Structures," and based on an example building with the following design parameters.

- Maximum building height = 40 ft.
- Basic wind speed = 115 mph
- Exposure Category = Exposure B
- Building Risk Category = Risk Category II
- Enclosure Classification = Enclosed
- Maximum roof slope = 2:12

GAF recommends a licensed design professional calculate fastener spacings using design parameters applicable to the specific building.

Example Fastener Spacing Guide for TPO/PVC Mechanically Attached Retrofit Roofing Systems

Roof Zone	Design Uplift ¹ (psf)	Fastener Spacing on center ³ (inches)		
		Steel Purlin Gage Thickness		
		16	14	12
Field of Roof	31	24 ⁴ /12 ⁵	24 ⁴ /12 ⁵	24 ⁴ /12 ⁵
Perimeter ²	52	20	24	24
Corner ²	78	16	18	18

1. Factor of Safety of 2.0 included.
2. If half sheets are used, corner and perimeter may need up to three half sheets at 5 ft. each, depending on building geometry (licensed design professional to calculate number of half sheets needed).
3. Allowable fastener load per TPO/PVC attachment tables; minimum pullout (lbs/fastener).
4. Spacing for fastening roof membrane to every purlin; maximum 5 ft. apart.
5. Spacing for fastening roof membrane to every other purlin; maximum 10 ft. apart.